

Large Transmitting Arrays for Deep Space Uplinks, Solar System Radar, and Related Applications

Larry R. D’Addario

Jet Propulsion Laboratory, California Institute of Technology
M/S 11-116, 4800 Oak Grove Drive, Pasadena, CA 91109, USA
Email: ldaddario@jpl.nasa.gov

Abstract— NASA’s Deep Space Network is now being re-designed to provide the next generation of ground based equipment for communicating with spacecraft throughout our solar system. In the receiving direction, it seems clear that large arrays of relatively small antennas provide the most cost-effective method of increasing the interplanetary data rate by at least 100 times over present capabilities, as is now desired. In the transmitting direction, data must also be sent at increasing rates, and the best approach to this is now being studied. Two-way links are also important for supporting spacecraft navigation and radio science measurements. Furthermore, the ability to generate very high effective radiated power makes possible radar studies of planets, asteroids, and other objects. This paper describes a conceptual design for arrays of antennas that provide transmitting capability to deep space for all these purposes.

Disclaimer— Opinions expressed in this paper are those of the author. They are not necessarily endorsed by JPL or NASA. The design presented has not been selected for implementation, and other possibilities are also under consideration.

INTRODUCTION

Examples of present and future transmission capabilities in the 7.2 GHz space research band are listed in Table 1. The main facilities of the present Deep Space Network (DSN) are 70 m and 34 m diameter antennas with 20 kW power amplifiers at three locations around the world. These systems, especially the 70 m antennas, are nearing the ends of their useful lives and must soon undergo major refurbishment or be replaced. Replacement with an array of smaller antennas now appears to be the best choice; it is much less expensive for the same effective isotropic radiated power (EIRP), and it is expandable to much larger EIRPs. Fig. 1 shows the implications of this for data transmission to interplanetary spacecraft. We consider two cases: routine data transmission, where the spacecraft carries a high gain antenna pointed at Earth and the largest feasible data rate is desired; and emergency transmission, where the spacecraft orientation is uncertain so that an omnidirectional antenna is used, but where a data rate of only 8 bits per second is adequate for the transfer of recovery commands. The routine case is calculated with a spacecraft antenna of 1.0 m² effective area, although larger antennas are often possible. With modern spacecraft electronics and with 1.0 TW of EIRP on Earth, routine data rates can be increased by a factor of more than 2000 over current practice and emergency support can be extended nearly to the edge of the solar system.

It is predicted that as many as 15 interplanetary missions will be operating simultaneously in 2015, and 45 in 2030. Thus, much of the increased capacity will be needed to support multiple spacecraft, rather than to increase data volume to any one of them. The DSN will continue to maintain three or more similar facilities around the world, allowing the load to be shared among them. For downlinks, simultaneous support of multiple spacecraft from one station can be achieved by partitioning an array of antennas into subarrays; performance of each subarray is proportional to its number of antennas. But for uplinks this would be very inefficient because a subarray of N_i identical antenna systems provides an EIRP of $E_i = GPN_i^2$, where G is the gain of each antenna and P is the power delivered to it. The total $\sum_i E_i$ is always less than it is with all antennas in the same array, producing $E_{\max} = GP(\sum_i N_i)^2$. Efficient use can be achieved if the array is partitioned by time rather than

Table 1: Transmission Systems at 7.2 GHz

Diameter	Power	No. in array	EIRP	
70m	20 kW	1	360 GW	existing
34m	20 kW	1	85 GW	existing
12m	2 kW	31	1 TW	possible future
3.8m	430 W	217	1 TW	possible future

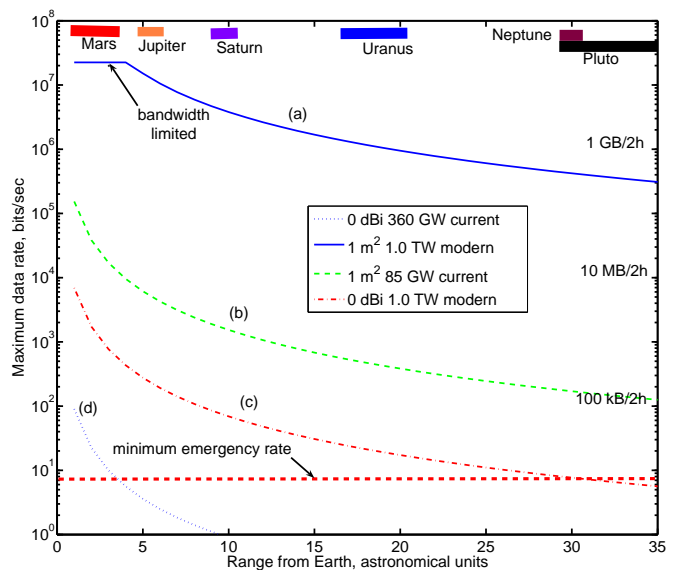

Fig. 1: Present and future transmission performance at 7.2 GHz. (a,b): Routine transmission with space antenna effective area 1.0 m². (c,d): Emergency transmission with omnidirectional space antenna. (a,c): Modern spacecraft electronics and 1.0 TW earth station; error correction code for routine case only. (b,d): Existing spacecraft electronics, 85 GW routine, 360 GW emergency, no coding.

by antennas, so that the various spacecraft are supported sequentially at E_{\max} rather than simultaneously at lower power. Fig. 1 also shows the data volume that can be transmitted in 2 hours; with three stations, up to 36 such transmissions can be provided each day. The ratio of uplink to downlink data volume varies widely among spacecraft; for this reason, the ground systems for uplink and downlink should use separate antennas.

In addition to the transfer of data, uplink signals are needed to support spacecraft navigation via two-way range and Doppler measurements and to support certain radioscience experiments such as measurements of transmission through planetary atmospheres. For these purposes, a narrow-bandwidth signal is generally sufficient (either a single sinusoid or a carrier with a few sidetones), and therefore the required EIRP is less than for high-rate data transfer. Conversely, radar measurements of planets and asteroids can benefit from much higher EIRP. At present the 70 m antenna at Goldstone, California includes a 500 kW radar transmitter at 8.6 GHz, producing about 8 TW of EIRP. The equivalent can be provided by adding antennas to one of the arrays in Table 1. However, if the receiving array now planned for downlink communication [1] is used for the radar return signal, the sensitivity will be improved by a factor of about 10. With 1.0 TW of EIRP for radar transmitting, a net improvement of about 25% over the present capability is achieved. Expansion of the transmitting array to at least 10 TW is straightforward, but costly. Further expansion may be limited by atmospheric turbulence as the geographical extent increases.

This paper is limited to systems operating in the space research uplink band near 7.2 GHz and the radar band near 8.6 GHz. Deep space transmission at higher frequencies, especially the space research allocation near 34 GHz, is also of interest. However, achieving high EIRP using arrays of antennas is difficult at such frequencies because of turbulence in the Earth's atmosphere. For applications needing relatively low EIRP, including most navigation and radio science, moderate size (10–20 m) single antennas are cost-effective.

CONCEPTUAL DESIGN

For a given $E_{\max} = GPN^2$ there is a combination of antenna gain G (and hence size, measured by diameter d), power P , and number of antennas N that minimizes the total construction cost. If we restrict attention to reflector (dish-like) antennas, cost models indicate that for $E_{\max} = 1.0$ TW the minimum is spanned by systems from $\{d, P, N\} = \{3\text{m}, 300\text{W}, 330\}$ to $\{12\text{m}, 4000\text{W}, 23\}$. In the absence of detailed designs, the cost models contain considerable uncertainty, so the optimum choice is not accurately known. Here we have selected for study a design with $\{d, P, N\} = \{3.8\text{m}, 430\text{W}, 217\}$. It is not claimed that this is optimum in any sense, but only that it is a practical, relatively low cost choice. The design to be implemented for the DSN has not yet been selected.

To minimize the effects of atmospheric turbulence, the array should be as compact as possible. Therefore we propose to arrange the antennas on a triangular grid. To prevent shadowing at an elevation angle e_0 , the grid spacing should be at least $d/\tan e_0$. The resulting configuration is plotted in Fig. 2 for $d = 3.8$ m and $e_0 = 10^\circ$. The overall extent of the array is about 340 m.

To achieve coherent combining of the signals from the array's separate antennas at the target spacecraft, the carrier phase and modulation timing of the signal delivered to each antenna must be accurately controlled. Variation of the required settings with target direction is determined by geometry and can be calculated if the antenna positions are known. It is also necessary to know the offset of each antenna's phase and timing from its nominal value. It is not practical to make these offsets sufficiently small by design and construction, so they must be calibrated *in situ*. Furthermore, the phase (and to a lesser extent the timing) is subject to variation with stresses such as temperature changes and antenna movement, so the calibrations must be repeated periodically. The biggest challenges in the array design are to establish accurate calibration methods and to ensure that the system is stable enough that the necessary calibration interval is not too short.

Calibration

We propose to calibrate the array by transmitting to a cooperating receiver at a known location. All antennas (or a large subset) can be calibrated simultaneously by modulating each with a different pseudo-random bit sequence via BPSK. The receiver can then separately recover each carrier and each PRBS and measure their relative phases and timings. There are several possibilities for the location of the calibration receiver. It cannot be in deep space because of the long round-trip signal time. It could be in earth orbit or airborne, but then its position is difficult to determine accurately, especially for low earth orbits where motion is rapid. It is therefore proposed that the receiver be on Earth, mounted on a tower near the array. The receiving antenna must be high enough to have an unobstructed view of all antennas without excessive multipath interference, and its distance must be beyond the near field region so as to avoid large phase and gain variation with small pointing

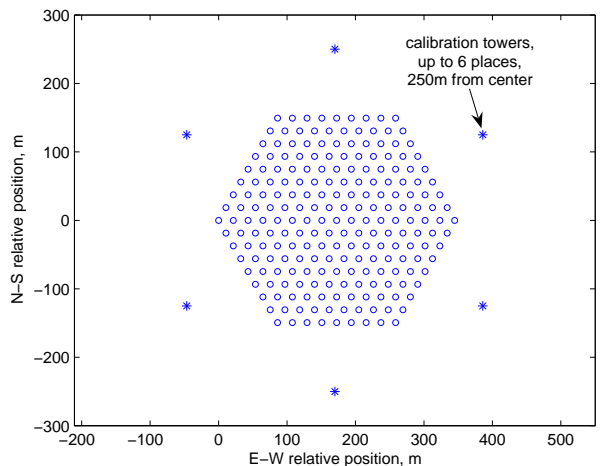

Fig. 2: Configuration of the 271 element array of 3.8 m diameter antennas. The spacing is chosen to avoid shadowing above 10 degrees elevation. The closest feasible locations of calibration receivers are also shown.

errors. Calculations [2] suggest a minimum distance of $d^2/4\lambda$ for wavelength λ , or 76.5 m for $d = 3.8$ m at 7.2 GHz. Feasible locations are plotted in Fig. 2. These are 250 m from the array’s center, 103 m from the nearest antenna, and 406 m from the farthest antennas. A tower height of 109 m then ensures that the central ray from each antenna misses all other antennas by at least d ; from the farthest antenna, the elevation of the receiver is 15° . The receiving antenna is a simple conical horn with beamwidth about 60° horizontally and 30° vertically.

A single calibration receiver is sufficient to determine all the phase and timing offsets (relative to those of one antenna selected as “reference”) if the array antenna positions and the calibration receiver’s antenna position are accurately known. Initially, all the positions can be established within a few cm by optical and GPS surveying, but this will not be adequate as the final calibrator (see Table 2 below). If three calibration receivers are placed at different azimuths, then the additional measurements can be used to refine the horizontal coordinates of the array antennas. With four receivers, it is in principle also possible to refine the positions of the receiving antennas, and the results are then significantly overconstrained. We propose to have four receivers. However, accurate determination of the vertical coordinates of most array antennas is difficult because of the shallow angles imposed by the geometry. For those values, transmission to a distant spacecraft carrying a broad-band transponder can be used. The antenna positions are very stable, so this is needed infrequently; a deep space object is acceptable in spite of the round trip propagation time.

Error Budget

Errors in aligning the carrier phases will cause a loss in EIRP. If the errors are independent among the antennas, then with a large number of antennas the EIRP is reduced by a factor of $\exp(-\sigma^2/2)$, where σ is the rms phase error. A reduction of -0.5 dB is considered acceptable. The major sources of error are listed in Table 2, along with a budget that limits the total to -0.45 dB if the sources are independent. The allocation to the atmosphere is based on a study of the effect of atmospheric turbulence on microwave phase using data from radiotelescope sites [3]. The other allocations are engineering judgments and are believed to be practical, but they have not yet been demonstrated. The items involving change of instrumental phase since the last calibration are time dependent; they are certainly achievable for short calibration intervals, but it will be operationally inconvenient if intervals of at least a few hours are not achieved. A design goal is to maintain this budget for any 8 hour period.

Table 2: Phase Error Budget for Each Antenna

Description	rms error	radians@7.2GHz	Notes
Knowledge of array antenna position	0.8 mm	0.12	
Knowledge of calibration target position	0.8 mm	0.12	
SNR in phase measurement	40 dB	0.01	[a]
Atmosphere during calibration	0.2 mm	0.03	[b]
Atmosphere during target tracking	2.1 mm	0.32	[c]
Electronics phase change since last cal	2.0 mm	0.30	
Structure phase change since last cal	0.55 mm	0.08	
Total rss phase error		0.478	
Total loss factor	-0.45 dB		

Note [a]: Effect of SNR will be larger if solving for calibration receiver locations.

Note [b]: Requires knowledge of local air temperature and pressure.

Note [c]: Based on VLA data [3], at 98th percentile and 20 deg elevation.

Architecture For Electronics

Electronics for generation of the desired signal waveform at each antenna can be remarkably simple. We take advantage of an architecture involving a multi-phase oscillator operating directly at the RF carrier frequency and coupled to a high-speed switch that selects one of 16 equally-spaced phases for transmission, as shown in Fig. 3. Such circuitry has been implemented at 19 GHz in SiGe BiCMOS [4] and in Si CMOS [5] as part of a custom MMIC for a phased array receiver. All of the required phase tracking and any desired phase modulation is produced by driving the switch control with the appropriate sequence of 4-bit values. These are generated in a single high-speed FPGA. Thus, all the signal processing for one antenna is handled by two integrated circuits. The output is filtered and delivered to a power amplifier. The oscillator is phase-locked to a fixed-phase RF reference transmitted from a central master oscillator via optical fiber; the same reference is delivered to all antennas of the array. The reference path is stabilized by returning a copy of the signal to the center over an identical path and keeping the round-trip phase constant.

The data for transmission are distributed from a central computer as ethernet packets, and these are also identical for all antennas. Data bits are stored in the FPGA and used to modulate the phase-control sequence at the times required to ensure that bits from all antennas are aligned at the distant spacecraft. Control information for the antenna, including phase tracking and modulation timing, is also sent as ethernet packets;

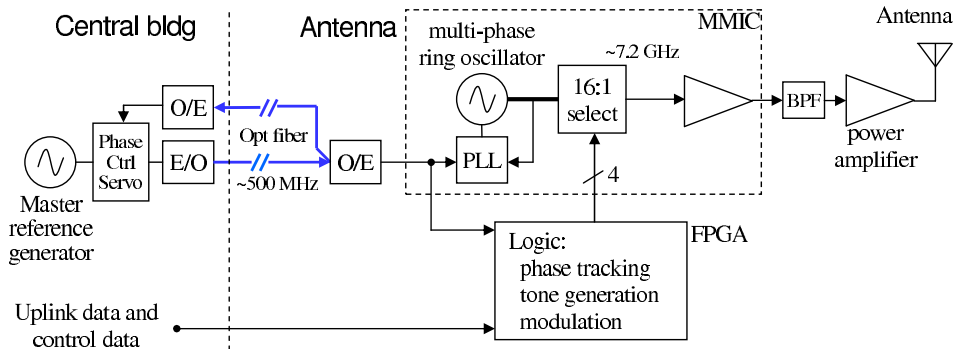

Fig. 3: Simplified block diagram of electronics for each antenna.

these are antenna-specific, but normally they are a very small fraction of the data flow. Timing is accurately maintained because the clock for the digital logic is a component of the distributed reference signal.

This arrangement results in a compact electronic assembly that can be located at each antenna close to the power amplifier. It can be kept under tight environmental control so that phase and delay drifts are minimized. The cost is expected to be only a few percent of the cost of an antenna and power amplifier, even for the 3.8 m antenna size.

ALTERNATIVE DESIGNS

The design described here is believed to achieve the lowest cost for $E_{\max} = 1.0 \text{ TW}$ if reflector antennas are used, but much lower cost may be possible by using sub-wavelength size printed antennas and $P < 0.1 \text{ W}$, as suggested by Scheffer [6]. Millions of these antennas would be required, but the arrangement has major advantages. Not only are the antenna elements inexpensive, but they need not be steered because their beams cover the entire sky. This means that no shadowing occurs, so the antennas can be closely packed. This allows the electronics for many antennas to be integrated into a single chip set (as demonstrated in [5]) and installed on the same printed board as the antennas without incurring large losses from long transmission lines. Whereas a 1.0 TW array would then be quite small (perhaps 50 m square at $P = 10 \text{ mW}$), arrays with far higher EIRP can be contemplated. For the DSN, however, the required technology is considered insufficiently mature. In particular, significant research is needed to arrive at an antenna element design that achieves large scan angles in a close-packed array without blind directions.

At the other extreme, the use of very large single antennas with high power transmitters can be considered. The largest feasible fully-steerable antenna is about 100 m in diameter, and safety considerations limit the peak power density in the beam to about 10 mW/cm^2 , limiting the power to about 250 kW and allowing an EIRP up to about 9 TW. The main objection to this is its high construction cost; it is estimated that a small-antenna array for the same EIRP would cost only 20% as much. A secondary consideration is reliability: the large antenna has many single points of failure, but the array degrades slowly as individual components fail.

CONCLUSION

A conceptual design has been described for a transmitting array of small antennas producing an aggregate EIRP of 1 TW at 7.2 GHz. A feasible calibration method has been proposed. Several such systems distributed around the Earth will provide greatly increased data transmission capacity to deep space, and will maintain our capability for solar system radar studies.

REFERENCES

- [1] D. Bagri, "Array-based deep space network for NASA," this conference. Also, M. S. Gatti, "The Deep Space Network Large Array." *Interplanetary Network Progress Report*, vol 42-157, 2004; http://ipnpr.jpl.nasa.gov/tmo/progress_report/42-157/1570.pdf.
- [2] Vahraz Jamnejad, "A Study of Near to Far Fields of JPL Deep Space Network (DSN) Antennas for RFI Analysis." *IEEE Aerospace Conference*, Big Sky, Montana, March 6-13, 2004.
- [3] L. R. D'Addario, "Estimates of Atmosphere-Induced Gain Loss for the Deep Space Network Array." *Interplanetary Network Progress Report*, vol 42-160, 2005; http://ipnpr.jpl.nasa.gov/tmo/progress_report/42-160/160E.pdf.
- [4] Hossein Hashemi, Xiang Guan, Abbas Komijani, and Ali Hajimiri, "A 24-GHz SiGe Phased-Array Receiver-LO Phase-Shifting Approach." *IEEE Trans. Microwave Theory and Tech.*, vol 53, pp 614-626, 2005.
- [5] Xiang Guan, Hossein Hashemi, and Ali Hajimiri, "A Fully Integrated 24-GHz Eight-Element Phased-Array Receiver in Silicon." *IEEE J. of Solid-State Circuits*, vol 39, pp 2311-2330, 2004.
- [6] L. K. Scheffer, "A High Power, Low Cost Transmitter for Deep Space Applications." To appear in *Radio Science*, 2005.