

Ka-band Digital Beamforming and SweepSAR Demonstration for Ice and Solid Earth Topography

Gregory Sadowy, Jet Propulsion Laboratory, California Institute of Technology, USA
Hirad Ghaemi, Jet Propulsion Laboratory, California Institute of Technology, USA
Brandon Heavy, Jet Propulsion Laboratory, California Institute of Technology, USA
Dragana Perković, Jet Propulsion Laboratory, California Institute of Technology, USA
Momin Quddus, Jet Propulsion Laboratory, California Institute of Technology, USA
Mark Zawadzki, Jet Propulsion Laboratory, California Institute of Technology, USA
Delwyn Moller, Remote Sensing Solutions, USA

Abstract

GLISTIN is an instrument concept for a single-pass interferometric SAR operating at 35.6 GHz. To achieve large swath widths using practical levels of transmitter power, a digitally-beamformed planar waveguide array is used. This paper describes results from a ground-based demonstration of a 16-receiver prototype.

Furthermore, SweepSAR is emerging as promising technique for achieving very wide swaths for surface change detection. NASA and DLR are studying this approach for the DESDynI and Tandem-L missions. SweepSAR employs a reflector with a digitally-beamformed array feed. We will describe development of an airborne demonstration of SweepSAR using the GLISTIN receiver array and a reflector.

1 Introduction

This paper describes recent developments in ground-based and airborne digitally-beamformed (DBF) radar demonstrations. This work was initially conducted under the NASA Instrument Incubator Program (IIP) as part of a technology demonstration for the mission concept: “Glacier and Land Ice Surface Topography Interferometer” (GLISTIN) and has continued with support of the DESDynI mission. GLISTIN is a Ka-band (35 GHz) spaceborne interferometric synthetic aperture radar (InSAR) that uses digital beamforming to provide a wide measurement swath[1]. In the GLISTIN concept, a 1m x 4m slotted waveguide antenna (oriented with the long dimension along track) is used to sample 16 simultaneous cross-track sub-swaths. This is achieved by illuminating the full-swath on transmit using a fan-beam radiator. The receive aperture is divided into 16 parts (called sticks) in the cross-track direction with each stick containing a downconverter and digital receiver. The data from all 16 sticks is then used to form 16 simultaneous cross-track beams.

Initially, a 1m x 1m aperture with 16 receiver channels was constructed and tested in a ground-based configuration. Digital beam formation was demonstrated using a calibration source and echoes from natural and man-made targets. The results from this demonstration are described in Section 2.

In addition to interest in DBF techniques that use a planar aperture format (like GLISTIN) there is growing interest in using DBF linear arrays to illuminate a parabolic reflector. This concept (called SweepSAR) is being studied for implementation in the DESDynI (NASA) and Tandem-L (DLR) missions [2]. While the addition of reflector fundamentally changes the nature of beam formation process, similar hardware and many of the same techniques are applicable. In order to conduct fundamental demonstrations and provide a testbed for studying the SweepSAR measurement technique and associated algorithms and hardware, an airborne SweepSAR system is being developed. This system will operate at Ka-band (35.6 GHz) and will use much of the hardware developed for the GLISTIN demonstration. The digital receiver system will be combined with the SAR hardware testbed developed for the NASA Uninhabited Airborne Vehicle Synthetic Aperture Radar (UAVSAR) and integrated on the NASA DC-8 Airborne Laboratory. The latter part of this paper will describe the design and development of this airborne SweepSAR demonstration.

2 Planar DBF demonstration

2.1 Hardware Description

The GLISTIN ground-based demonstration employed a 1m x 1m slotted waveguide array consisting 16 receiver sticks and one transmitter stick. The 17 sticks were fabricated in 8 mechanical panels, in a 4 (in elevation) by 2 (in azimuth) configuration. The number and size of these panels was dictated by the need to maintain flatness during manufacturing.

The radiating panels were assembled onto a structural frame. The rear side of the frame carried an array of receivers, local oscillator (LO) distribution, a wave-form generator (WG), upconverter, solid-state power amplifier (SSPA) and power supplies. A picture of the integrated DBF radar is shown in Fig. 1.

The key element for digital beamforming is the



Figure 1. 1m x 1m Array on JPL Mesa Range

receiver array. Each of the 16 receivers maintains a downconverter from Ka-band to L-band (1.25 GHz) followed by a bandpass-sampling digital receiver. The choice of input frequency for the digital receiver was driven by the performance of currently available analog-to-digital converters (ADCs) as well as the desire to use the receivers for L-band radar applications in follow-on tasks. A single digital receiver is shown in Fig. 2.



Figure 2. Digital Receiver (one of sixteen)

programmable gate array (FPGA). The ADC samples at 240 MS/s and has an analog input bandwidth of 1.5 GHz. The sampling process effectively downconverts the 1.26 GHz center frequency to baseband in-phase and quadrature (IQ) samples. These IQ samples are transferred to the FPGA where filtering can be applied. Finally, the data from all 16 receivers are transferred to a data aggregator board via a parallel Front-Panel Data Port (FPDP) bus. The aggregator multiplexes all of the data into a single stream and transmits it to the data recorder over a fiber-optic serial FPDP link.

2.1.1 Ground-based Demonstration

The system was initially staged in the laboratory and each receiver was fed by input signals from a single source at Ka-band using a 16-way splitter. No effort was made to equalize the phases of the input signals. The design assumes that initially unknown phase and amplitude offsets will exist between the receive channels and they must be calibrated out. The key is to achieve calibration stability so the calibration process need only be performed infrequently.

Data was collected over several days, which included power cycling the entire system. Measured signal phases were compared from different data collections and were found to agree with each other to within 2°, with the exception of a few of the outer elements. This was traced to signal integrity problems on the parallel FPDP bus which resulted in sample misalignment. This will be addressed in the follow-on development phase by subdividing the array into four 4-element FPDP busses instead of one 16-element bus. In the interim, our ground based experiment only utilized data from 12 receivers spread over a continuous 75 cm aperture length.

After confirmation of system stability, the system was staged on the JPL Mesa Antenna Range. The Mesa Range provides opportunities for calibration using a far-field source with minimal multi-path interference and unobstructed views of surrounding terrain for receiving echoes.

The primary objectives of this were to 1) demonstrate calibration and digital beam formation and 2) demonstrate functionality of beam forming as a full radar system by collecting echoes from surrounding terrain.

To demonstrate calibration and beamforming using the receiving system, a CW source was mounted approximately 360 m from the antenna under test (AUT) location. The AUT was mounted on an azimuth-over-elevation antenna positioner. Manual adjustment was used to find the boresight of the receive element pattern. Data was collected on all receivers with the AUT fixed in the boresight position. Subsequently, the AUT

was rotated in the azimuth plane to form a pattern cut across the DBF array.

Using data collected at boresight for calibration, fifteen beams over a range of -5° to $+5^\circ$ were formed. With no amplitude weighting applied, the half-power beamwidth of the digitally-formed beams was 0.5° , as expected for a uniformly illuminated array of 75 cm length at Ka-band. Figure 3 shows the azimuth patterns over a digital scan range. The broad peak is the measured pattern of a single receive element and the

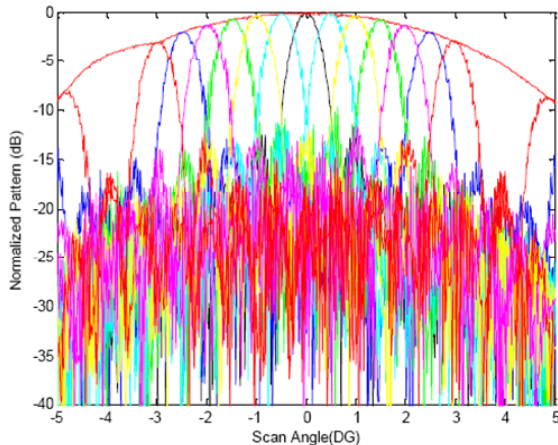

Figure 3. Digitally synthesized beam patterns

narrow peaks are digitally formed beams at various angles. The peak sidelobe level was approximate -13 dB; as expected for uniformly illuminated array. Pattern symmetry was excellent and no spurious lobes were observed.

3 Airborne SweepSAR Testbed

The measurement technique known as ‘‘SweepSAR’’ uses a parabolic reflector that is illuminated by a linear array feed whose center is typically at the focus of the parabola. Each array element illuminates the entire reflector and forms a beam with a radiation angle that is related to each element’s distance from the focus. This approach works well over a limited angular range where slight defocussing is tolerable. This technique provides high receive gain using digital beamforming on a relatively small array and thus reduces peak and average transmitter power requirements[2]. This configuration is currently being studied by both NASA and DLR for implementation on the DESDynI and Tandem-L missions.

The objectives of our current work are to provide an airborne SweepSAR testbed that can: 1) be used to study performance tradeoffs and algorithms for calibration, beamforming and mitigation of image gaps due to transmitter pulsing or failure of transmit or receive elements and 2) demonstrate performance of digital receivers beamformers and real-time hardware implementation of algorithms.

To achieve these objectives, it is essential to implement a SAR imaging system so that the effects of artifacts due to non-ideal performance of hardware and algorithms can be thoroughly studied. In order to keep the reflector sizes reasonable for an airborne demonstration, 35.6 GHz was chosen as the operating frequency. This allows us to use the previously described digital receiver system and also allows us to approximately scale the reflector by frequency based on the current DESDynI study designs.

To reduce development time and cost, we are leveraging the design, software and infrastructure of the NASA Uninhabited Airborne Vehicle Synthetic Aperture Radar (UAVSAR)[3]. The UAVSAR system provides high-speed data acquisition and storage, data take sequencing/control, high-rate platform attitude and position measurement and a radar operating interface.

A summary of the radar parameters is given in Table 1. Transmit power will be generated by an 800W peak power travelling wave tube amplifier (TWTA) and fed to a 2 cm x 40 cm slotted waveguide antenna which produces a fan beam which is narrow in the along-track directions and wide in the cross-track dimension. The receiver will use a 40-cm offset-fed reflector with a 2x16-element microstrip array feed. Each pair of elements has a low-noise amplifier (LNA) in order to mitigate feedline losses. The feed also incorporates distribution of a calibration signal in order to mitigate effects of LNA phase drift.

Table 1. Airborne SweepSAR System Parameters

Parameter	Value
Reflector Diameter	40 cm
Feed Length	10 cm
Number Feed Elements	16
Transmitter Power	800W
Flight Altitude	10 km
Look Angles	22° to 38° from Nadir
Noise-equivalent Normalized Radar Cross-section	-33 dB

The transmitting antenna, reflector and feed will be mounted inside a pressure box in the cargo bay of NASA’s DC-8 Airborne Laboratory. Sixteen small coaxial cables are used to route the LNA outputs to feedthroughs on the top of the pressure box. The digital receivers, TWTA and Inertial Navigation System (INS), will reside on top of the pressure box in the shirt-sleeve environment of the cargo bay. The UAVSAR data collection system and operator work stat will be placed in the DC-8 cabin. A block diagram showing this configuration is given in Fig. 4.

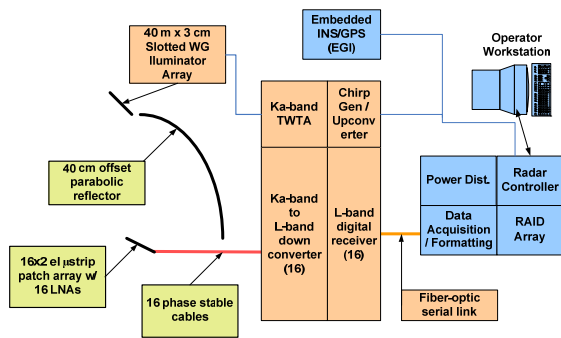

Figure 4. Airborne SweepSAR Block Diagram

The SweepSAR testbed will be capable of both raw data collection and real-time signal processing and digital beamforming. Each receiver contains a field programmable gate array (FPGA) that can be used to implement real-time filtering such as azimuth or range pre-summing or spectral remapping for split spectrum operation. Thus, each receiver can pass either processed or raw data to the data aggregator unit (DAU), which serializes and packetizes the data for transmission over optical fiber to the UAVSAR data collection system. The DAU also contains FPGAs which can be configured to implement real-time calibration and beamforming algorithms.

Initial flights will collect raw data on all channels. This will facilitate checkout and initial calibration of the system. Further raw data collections will be used to study and test calibration, processing and beamforming algorithms. The algorithms can then be implemented in the real-time processing hardware demonstrated in later flights. The system architecture also facilitates integration of new receivers and digital processors in order to demonstrate improvements in hardware implementation.

4 Summary

This paper described a Ka-band digitally beamformed array radar that was developed as a technology demonstration for the GLISTIN and DESDynI instrument concepts. Using a ground-based demonstration, we were able to show that the system produces high-quality received beams and exhibits stable calibration.

This digital beamforming radar system demonstration is now being used to develop an airborne SweepSAR Testbed that will be used to support algorithm, processing and hardware development for the DESDynI mission. The Airborne SweepSAR Testbed will fly on the NASA DC-8 Airborne Laboratory. It will collect raw data on sixteen simultaneous receiver channels and, optionally, perform signal processing and beam formation in real time.

References

- [1] Moller, D.; Heavey, B.; Rignot, E.; Sadowy, G.; Simard, M.; Zawadzki, M.: *A Novel Ka-band Digitally Beamformed Interferometric Synthetic Aperture Radar for Glacier and Ice-sheet Topographic Mapping: Concept and Technology Development*, 7th European Conference on Synthetic Aperture Radar, Friedrichshafen, Germany, 2008
- [2] Freeman, A.; Krieger, G.; Rosen, P.; Younis, M.; Johnson, W.; Huber, S.; Jordan, R.; Moreira, A.: *SweepSAR: Beam-forming on receive using a reflector-phased array feed combination for spaceborne SAR*, IEEE Radar Conference, Pasadena, California, 2009
- [3] Hensley, S.; Wheeler, K.; Sadowy, G.; Jones, C.; Shaffer, S.; Zebker, H.; Miller, T.; Heavey, B.; Chuang, E.; Chao, R.; Vines, K.; Nishimoto, K.; Prater, J.; Carrico, B.; Chamberlain, N.; Shimada, J.; Simard, M.; Chapman, B.; Muellerschoen, R.; Le, C.; Michel, T.; Hamilton, G.; Robison, D.; Neumann, G.; Meyer, R.; Smith, P.; Granger, J.; Rosen, P.; Flower, D.; Smith, R.: *The UAVSAR Instrument: Description and First Results*, IEEE Radar Conference, Rome, Italy, 2008

Acknowledgement

This research was carried out at the Jet Propulsion Laboratory, California Institute of Technology, under a contract with the National Aeronautics and Space Administration.