

The Current Development Status of the Orbiting Carbon Observatory (OCO) Instrument Optical Design

Robert Haring ^a, Randy Pollock ^a, Brian Sutin ^a, David Crisp ^b
^a Hamilton Sundstrand 2771 North Garey Avenue, Pomona CA 91701;
^b California Institute of Technology Jet Propulsion Laboratory

ABSTRACT

The Orbiting Carbon Observatory, OCO, is a NASA Earth System Science Pathfinder (ESSP) mission to measure the distribution of total column carbon dioxide in the earth's atmosphere from an earth orbiting satellite. NASA Headquarters confirmed this mission in May of this year. The California Institute of Technology's Jet Propulsion Laboratory is leading the mission. Hamilton Sundstrand is responsible for providing the OCO instrument. Orbital Sciences Corporation is supplying the spacecraft and the launch vehicle. The optical design of the OCO¹ is now in the detail design phase and efforts are focused on readiness for the Critical Design Review (CDR) of the instrument to be held in the fourth quarter of this year. OCO will be launched in September of 2008. It will orbit at the head of what is known as the Afternoon Constellation or A-Train (OCO, EOS-Aqua, CloudSat, CALIPSO, PARASOL and EOS-Aura). From a near polar sun synchronous (~1:18 PM equator crossing) orbit, OCO will provide the first space-based measurements of carbon dioxide on a scale and with the accuracy and precision to quantify terrestrial sources and sinks of CO₂. The status of the OCO instrument optical design is presented in this paper. The optical bench assembly comprises three cooled grating spectrometers coupled to an all-reflective telescope/relay system. Dichroic beam splitters are used to separate the light from a common telescope into the three spectral bands. The three bore sighted spectrometers allow the total column CO₂ absorption path to be corrected for optical path and surface pressure uncertainties, aerosols, and water vapor. The design of the instrument is based on classic flight proven technologies. However, this simplicity does not overshadow the many challenges yet ahead for the instrument team to build, test, and integrate the OBA hardware.

1. INTRODUCTION

The Orbiting Carbon Observatory is a NASA sponsored Earth System Science Pathfinder (ESSP) mission that will make space based measurements of column CO₂ to monitor sources and sinks of this principle greenhouse gas. The mission is lead by the Jet Propulsion Laboratory. Hamilton Sundstrand Space Land and Sea will provide the instrument, figure 1. Orbital Sciences Corporation will provide the spacecraft and launch vehicle. Launch is scheduled for October 2007 from facilities at Vandenburg, California. The preliminary design of the instrument was completed last year and many long lead items are now in the procurement process. During the detailed design of the optical bench assembly, several important changes are being implemented to the optomechanical system prior to creation of the detailed fabrication documents. In addition, other improvements include the construction and test of a qualification grating assembly and the potential to perform lens sub-assembly thermal/vacuum alignment and focus verification prior to integration into the OBA assembly housing with the diffraction gratings. These improvements are discussed in addition to an overview of the key hardware elements that comprise the optical bench assembly. Updates of the current status of the ongoing detail design, hardware procurement, and comments on the challenges ahead are reported.

1.1 The Orbiting Carbon Observatory mission

OCO will be launched into a sun-synchronous near polar orbit that provides near global coverage at monthly intervals to make space-based measurements of atmospheric carbon dioxide with the precision, resolution, and coverage needed to

characterize the geographic distribution of CO₂ sources and sinks and to quantify CO₂ variability over the annual cycle. The mission will record, calibrate, validate, publish, and archive science data records and calibrated geophysical data products in the NASA ESE Distributed Active Archive Center for use by the scientific community.

1.2 Carbon Dioxide measurements from space

High-resolution spectra of reflected sunlight in the near infrared at the CO₂ bands at 1.61 μm and 2.06 μm and oxygen a-band at 0.760 μm are used to retrieve the column average CO₂ dry mole fraction, X_{CO_2} . The 1.61 μm CO₂ band provides the maximum sensitivity near the surface while the O₂ A-band and the 2.06 μm CO₂ bands provide information needed to determine surface pressure, albedo, atmospheric temperature, water vapor, clouds, and aerosols. The need for high spectral resolution, from a minimum of 17,000 for the A-band to 20,000 for the two CO₂ bands is driven by both sensitivity requirements and the need to minimize systematic errors in the retrieval. Figure 2 shows the typical spectral radiance profile of the spectra to be measured by the optical system.

1.3 Observing modes

OCO cycles between Nadir and Glint modes on 16-day intervals to cross calibrate observations. In the Nadir mode, the instrument will collect footprints directly beneath the spacecraft with an area of less than 3 km². The glint mode observes the solar radiance reflected specularly from the Earth's surface to improve the signal to noise ratio from the surface and other low albedo surfaces in these measurements bands. Additionally, Target mode points the instrument at specific well instrumented ground sites and is provided for in flight validation of the space-based measurements.. A 10.3 km swath at nadir is measured from a nominal orbit height of 705 km. The swath includes 8 cross-track samples of 20 pixels per sample. A rolling readout is incorporated resulting in the parallelogram shaped ground footprints.

2. OPTICAL BENCH ASSEMBLY DESIGN

The design of the optics is driven by a set of critical requirements, most of which remain unchanged from those presented at the instruments preliminary design review. The requirements are summarized in table 1, flowed down from higher-level mission science requirements. Chief among these requirements is the relatively high spectral resolution specified, >17,000 for the oxygen a-band spectrometer and >20,000 both the carbon dioxide spectrometers. These requirements are unusual for a dispersive spectrometer and usually left to the domain of the Fourier Transform spectrometer. The high throughput and low focal ratio requirements are driven by minimum signal to noise requirements needed for the mission science. The instrument acquires 8 cross-track samples of a minimum of 19 pixels each. The detector chosen for each CO₂ channel spectrometer is based on the HAWAII-IRG device produced by Rockwell Scientific Corporation. It consists of a 1024 by 1024 array of 18 μm -square pixels. The A-band spectrometer uses a silicon version known as the HyViSI detector. The detector size, the minimum spectral sampling requirement, and field of view establish the system focal length and spectrometer slit size. A shaded ray trace view of the complete optical design is pictured in the figure 3.

2.1 Design implementation

The OCO optical bench assembly, shown in figure 4, is an updated version of the preliminary design. The assembly contains three classic grating spectrometers sharing a common housing. Relay assemblies consisting (in order) of a dichroic relay, a band isolation filter, a linear polarizer, and an inverse Newtonian re-imager are fixed at the entrance of each spectrometer. The three relays share common hardware and the order of band separation is 2.06 μm CO₂, 1.61 μm CO₂, and 760 nm A-Band. The A-band uses a fold mirror instead of the dichroic element (it is the last in the relay optical path). Attached via titanium isolator tube to the first relay is a Telescope/collimator assembly. Except for the isolator, which is located in a collimated section of the relay beam path, all metering structures with powered reflective elements in the optical path are made of aluminum alloy to achieve an athermalized design. The telescope and the collimator function to compress the beam to allow room to package the optics and most importantly allow a field baffle at the telescope focus limit the amount of unwanted radiation entering the optical system – needed for stray light management. During the preliminary design two mirror beam compressors were evaluated but failed to provide an intermediate field stop, so they were dropped. The complete optical bench assembly is thermally isolated and suspended

inside an aluminum shroud. The shroud is actively cooled to maintain a uniform constant -5 C optical bench assembly temperature in all operation modes of the instrument.

2.2 Spectrometer design

The relatively narrow spectral range of each spectrometer channel, 25 to 40 nm, allows a very simple refractive based spectrometer solution consisting of a slit, refractive collimator, a plano reflection diffraction grating, and a refractive camera to re-image the spectral x spatial image. A scaled breadboard of the OCO A-band spectrometer was constructed and tested in 2002². It demonstrated very high spectral resolution, greater than 17,000, can be achieved using the simple design approach chosen for the OCO instrument spectrometers. An important goal maintained since the preliminary design phase has always been to keep the design simple. To keep things simple in this design means to keep the number of optical element to a minimum, use optical glasses that are readily available, keep the geometry of the optical path of the three spectrometers similar if not identical (if practical), and design to requirements. Today, the maturing “simple” optical design is shown to meet or exceed all requirements flowed from the OCO mission level requirements. The design approach yields a synergy not only in parts design but in the tools and techniques to sub assemble, align/focus, and test the OBA hardware through out the build process.

2.3 Telescope/relay design

The OCO instrument optical design is shown in figure 4. Light enters a single telescope, a classic F/1.8 Cassegrain design, and images the scene at the field baffle. The light is then collimated with a similar Cassegrain collimator with a shorter focal length to compress the pupil to a diameter that can be packaged within the volume constraints. This entrance optics design provides a common field of view for the three spectrometers. Since the telescope and re-collimator must work over the much broader spectral range, 0.76 to 2.06 μm , the all-reflective implementation is chosen to avoid complexities associated with refractive designs. The collimated beam passes the scene irradiance through a series of dichroic beam splitters to separate the two CO₂ bands from the oxygen a-band. Each band thus separated is re-imaged onto the entrance slit of a spectrometer. Figure 5 shows a close up section view of the telescope/collimator design.

2.4 Entrance Baffle/Calibration assembly design.

The OCO instrument has several provisions for spectral-radiometric calibration on orbit. These provisions are incorporated in the entrance baffle/calibration assembly, shown in figure 6. Depending on the particular mode of operation, a paddle shaped device is rotated into view of the instrument via a simple motor driven mechanism. The three functional modes provided are 1) covered or stowed, 2) science, and 3) solar calibration. In the covered mode, as the name implies, the instrument’s field of view of view is completely obscured. The instrument will be launched in the covered mode (the paddle is rotated 90° counter clockwise as pictured in figure 6) to protect the optics from contamination. The inside of the aperture cover is coated with a diffuse gold surface that is can be illuminated by three redundant lamps to produce an on-orbit “flat field” calibration. In the science mode the “paddle” is positioned as show in the figure to provide the instrument an un-obscured view of the scene for science retrievals. In the third mode, the mechanism rotates 90° clockwise so that the diffuser covers the entrance baffle for direct views of the sun to record the solar spectrum and on provide onboard radiometric calibrations. The entrance baffle is a classic straight vane design that serves several functions. First, it attenuates unwanted scattered light into the instruments optical path. Second, it provides a mount for a three-vane spider supported calibration lamp assembly. Finally, it provides thermal isolation since entrance baffle/calibration assembly will see the full solar irradiance. This assembly is not mechanically attached to the cooled optical bench assembly. Instead, it is mounted to the spacecraft and aligned to the instrument optical path at integration with the spacecraft. Redundant methods to verify the baffle assembly’s alignment with the telescope are provided in the design of the telescope assembly.

2.5 All reflective transmission diffuser design

OCO uses a unique all-reflective solar transmission diffuser. Although sunlight will enter the diffuser on one side and exit on the opposing side as it would in a ground glass transmission diffuser, this is accomplished via a multiple specular and diffuse reflection process. The details of the optical design and theory of operation of this device are beyond the scope of this paper. However, this stacked array of apertures and pyramid shaped mirrors and reflective

diffusers allows the irradiance profile filling the telescope entrance pupil to be tailored to perform solar calibration of the OCO spectrometers over their full dynamic range when in this mode and the instrument is oriented to view the sun directly. All surfaces in the diffuser are coated with vapor deposited gold.

2.6 Optical design performance

The performance of the typical OCO spectrometer is demonstrated in the spot diagram shown in figure 8. The design produces long narrow spots with an aspect ratio designed to maximize the resolution in the spectral direction, and produce some blurring spatial sampling direction, since approximately 20 pixels are combined to produce a single spatial sample. An updated y-enclosed energy plot, figure 7, of the 2.06 μm spectrometer optimized design shows 100% of the energy in the dispersion direction is contained within a distance of less than 4.5 μm from image centroid. At 2.06 μm this is less than diffraction limit. Each spectrometer, the A-band, and two CO₂ bands, was optimized using this technique. The predicted resolution of the A-band spectrometer is over 20,000, similar to the CO₂ channels. However, the A-band spectrometer slit has been widened to improve the throughput since the minimum resolution required in this channel (17,000 verses 20,000).

2.7 Spectral stray light

Simulations of the stray light performance of the OCO instrument are being performed using TracePro (Lambda Research Corporation). The expert version of the program is being put to use because it allows the use of tabulated BRDF (Bi-directional Reflectance Distribution Function) measurement data. Samples of several optical path materials including the diffuser, focal planes, and various types of painted aluminum samples to be used for finishing the pertinent surfaces in the instruments optical have been prepared and measured. Figure 8 is an example of the measured BRDF of a representative HgCdTe detector. These data are now being input into a complete model of the 760 nm A-band optical path. Figure 9 shows a view of the model, created from the current Pro-Engineer CAD model database. The specified RMS surface roughness for the spectrometer lenses and the grating scatter specification is included in the model. Although some initial modeling of the optical path was performed over a year ago supported the preliminary design, the higher fidelity and accuracy of the updated model is intended to provide assurance the materials, surfaces finishes, and the processes to produce them will result in an instrument that will exceed requirements. In addition, the quantitative nature of the simulation results will provide the science team data sets that provide an early indication of expected OCO instrument optical performance.

2.8 Instrument line shape

The requirements for instrument line shape are based the $W(x)$ function. The integral function used to numerically calculate this parameter for each spectrometer is shown in equation 1.

In the expression, the limits of the instrument normalized line shape function, ILS, are enumerated for $x = .5, 1.0,$ and 6.0 where x is the number of multiples of full widths at half maximum response, $\Delta\lambda$, the integration is carried out. For example, for $x=6.0$ the requirement is that a fraction of > 0.99 of the total integrated line shape be enclosed within 6 FWHM's from the line peak. Symmetric instrument line shapes are predicted for the OCO spectrometers. stray/scattered light reaching the image plane. However, preliminary design predictions, tabulated at the far right column of figure 12 indicate requirements are exceed and provide margin for stray/scattered light contributions.

Figure 1 The OCO Instrument

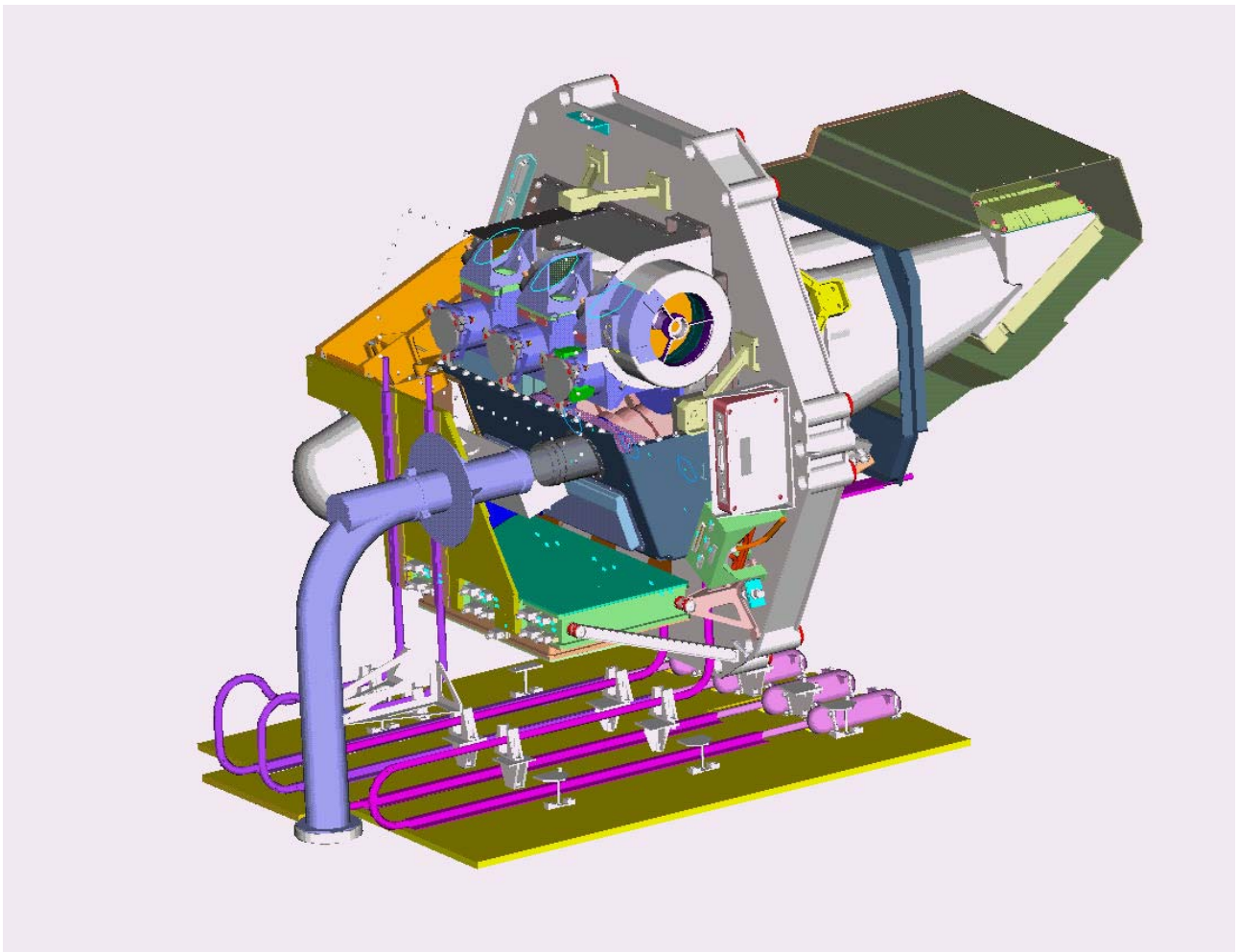

Figure 2 typical spectral radiance profiles

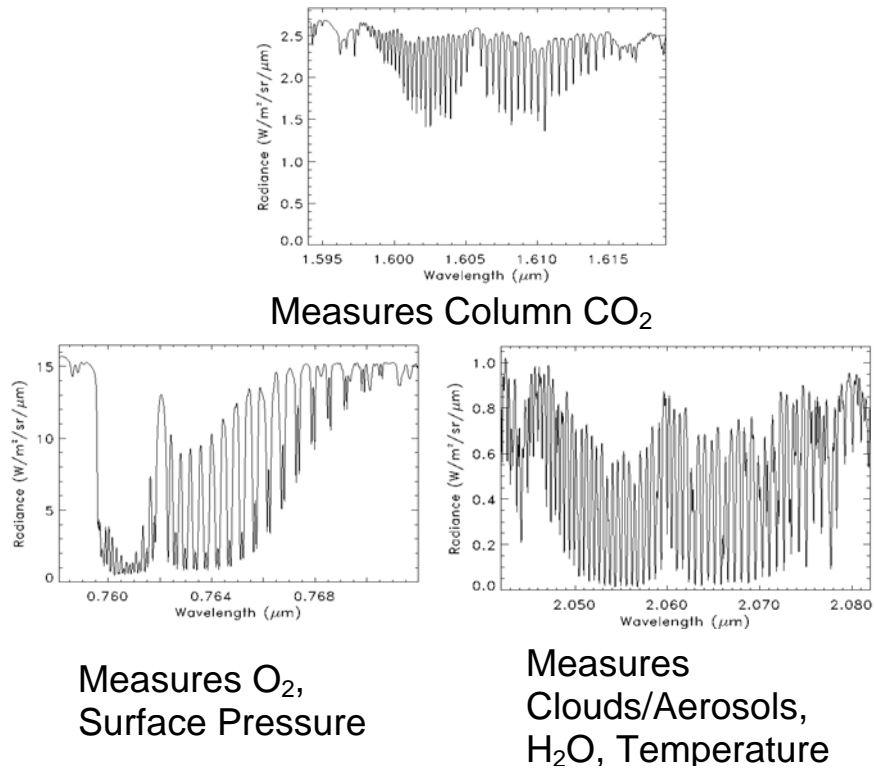

Table 1 OCO instrument optical requirements

ID	Requirement	Unit	0.76 μm O ₂		1.61 μm CO ₂		2.06 μm CO ₂	
			Specification	Prediction	Specification	Prediction	Specification	Prediction
L0514	Focal Ratio	-	≤ 1.9	1.8	≤ 1.9	1.8	≤ 1.9	1.8
L5016	Field of view	mrad	14.2 - 15.1	14.6	14.2 - 15.1	14.6	14.2 - 15.1	14.6
L5017	Samples	-	8	8	8	8	8	8
L5018	Pixels per Sample	-	≥ 19	20	≥ 19	20	≥ 19	20
L5019	Minimum Wavelength	μm	0.758	0.758	1.591	1.591	2.042	2.042
L5049	Maximum Wavelength	μm	0.772	0.772	1.621	1.621	2.081	2.081
L5020	Spectral Resolution	-	≥ 17,000	17,842 - 18,199	≥ 20,000	20,990 - 21,410	≥ 20,000	20,990 - 21,410
L5052	Spectral Sampling	pixels / sample	≥ 2	2.45 - 3.34	≥ 2	2.08 - 2.84	≥ 2	2.08 - 2.84
L5039	Optical Throughput TM(s) polarization	-	> 35%	35.5%	> 40%	41.5%	> 45%	46.3%

Figure 3 The OCO optical system

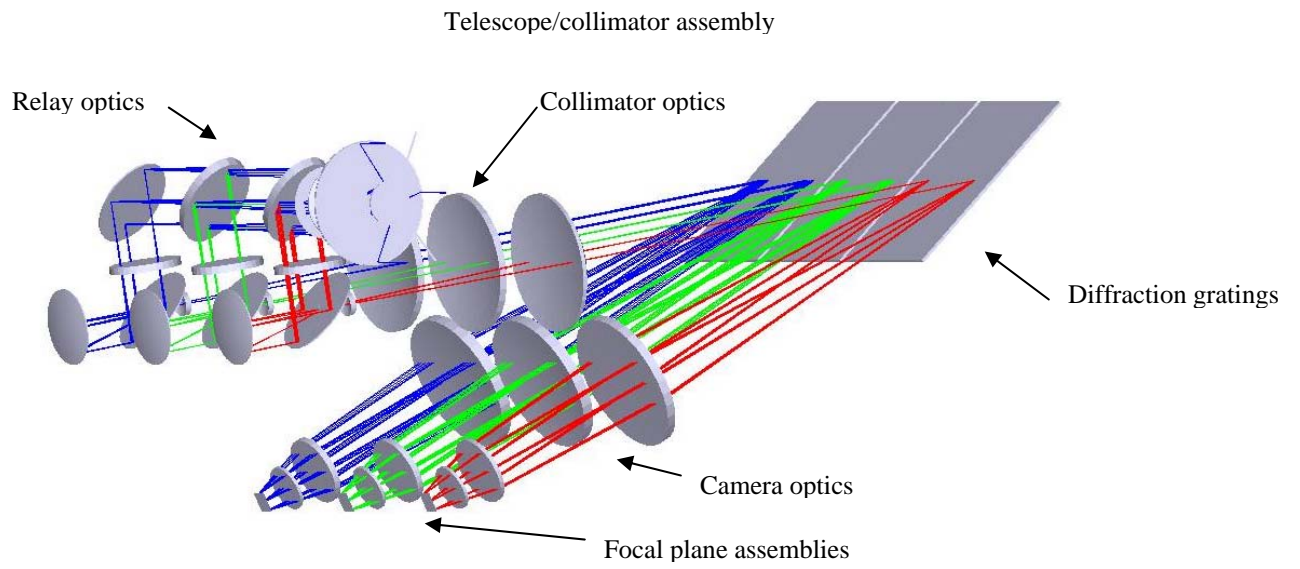

Figure 4 OCO Optical Bench Assembly (OBA)

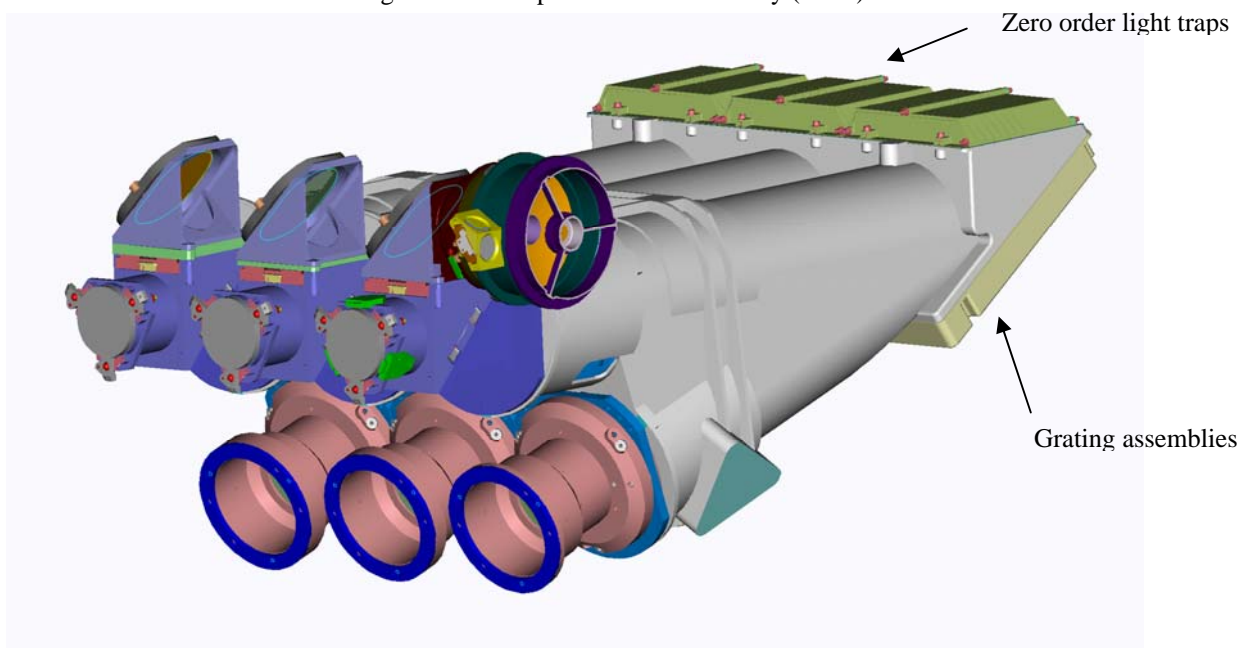

Figure 5 F/1.8 telescope and collimator section view

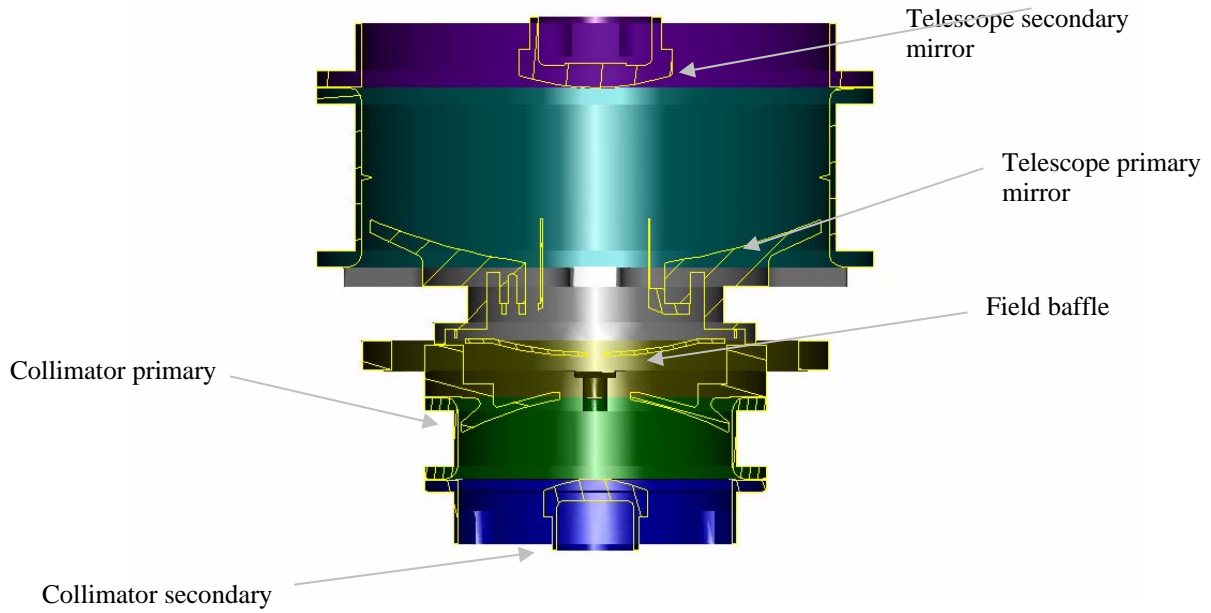

Figure 6 Entrance baffle/calibration sub assembly (science mode shown)

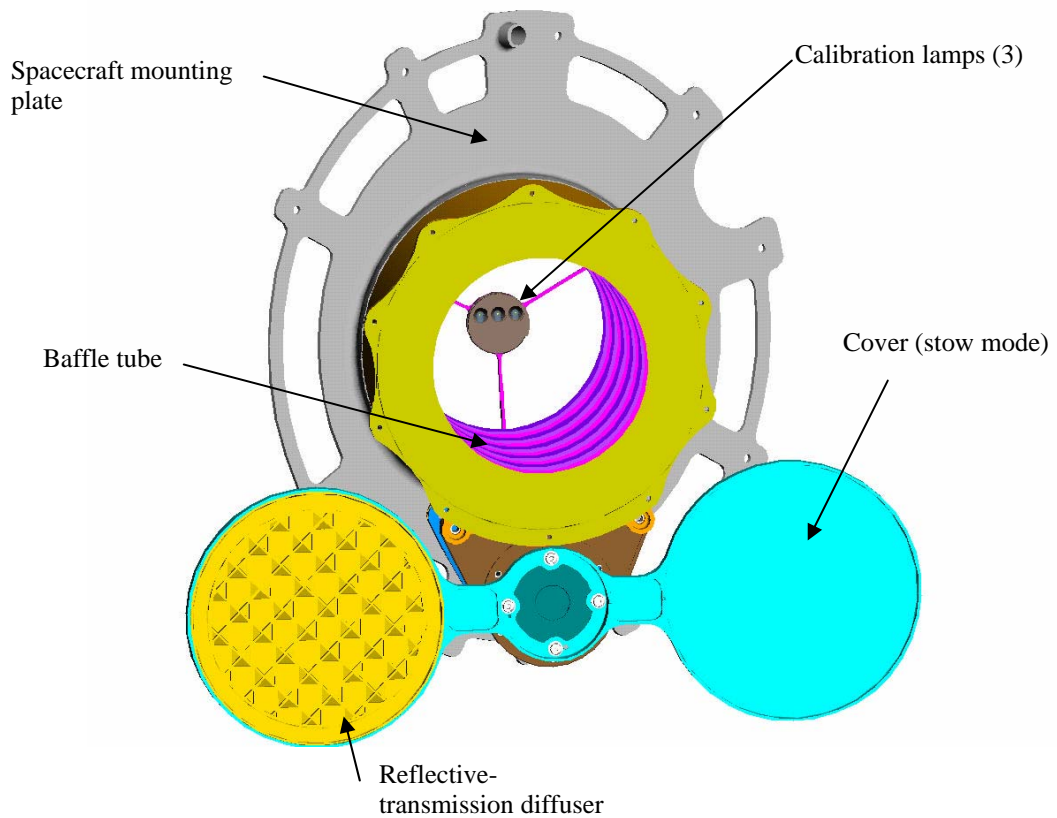

Figure 7 A-Band spectrometer Y-enclosed energy plot

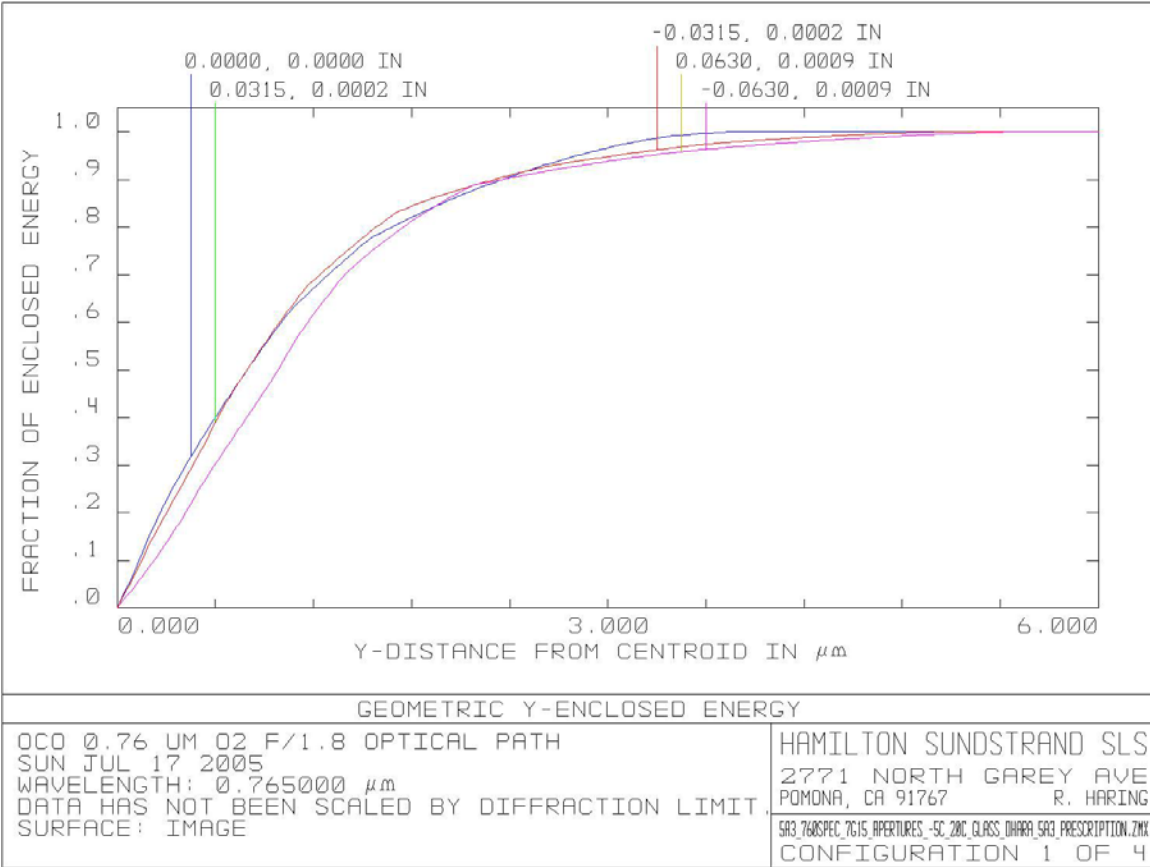

Figure 8 Mercury Cadmium Telluride Detector Bi-reflectance Disruption Function at 1.55 microns

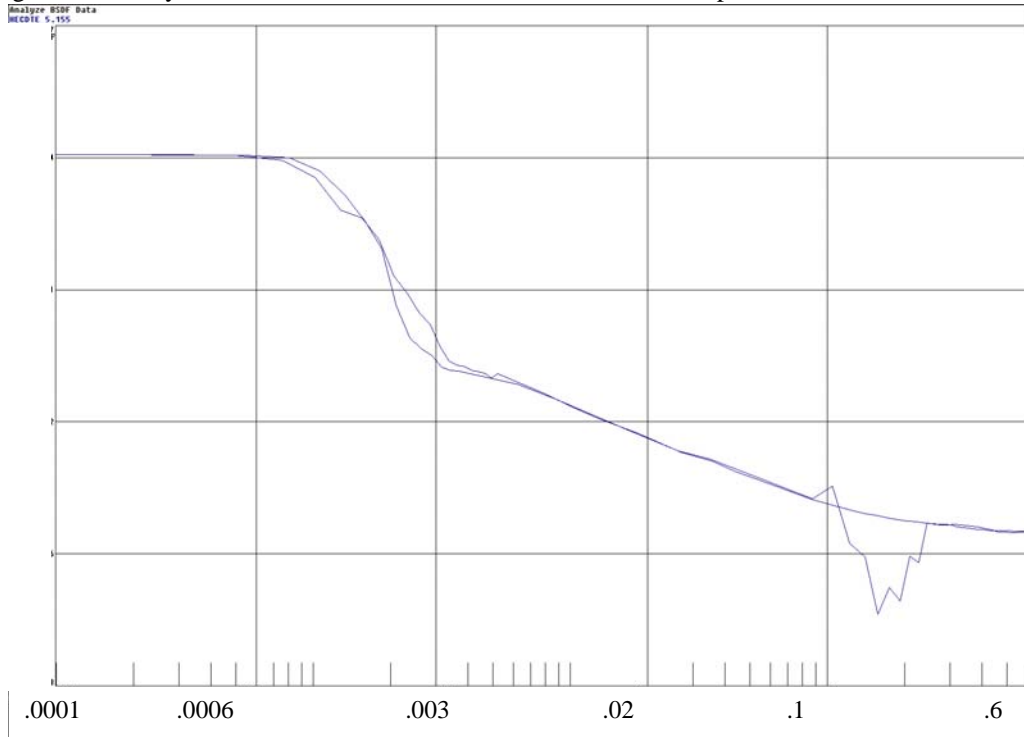
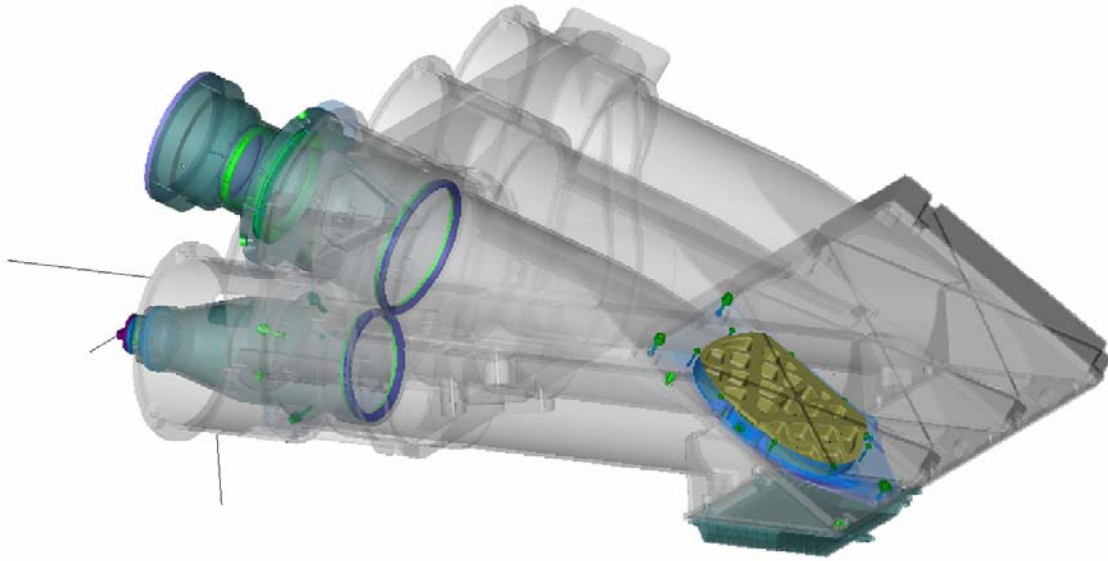

Figure 9 OCO instrument stray light model



SUMMARY

The development status of the optical design of the Orbiting Carbon Observatory instrument is presented. The cooled optical bench assembly comprised of three substantially similar refractive spectrometer designs coupled to an all-reflective single telescope/re-collimator entrance optic via a simple dichroic relay system is now in the detail design phase. The instrument CDR is scheduled for the fourth quarter this year. There are challenges ahead for the instrument team to fabricate, assemble, align, and test OCO instrument. However, the simple optical design approach chosen for this instrument in principle will make the effort manageable.