

A Membrane Array Using T/R Membranes

Alina Moussessian, Linda Del Castillo, John Huang, Greg Sadowy, James Hoffman, Phil Smith, Toshiro Hatake, Chuck Derksen, Bernardo Lopez, Soren Madsen

Jet Propulsion Laboratory, California Institute of Technology, Pasadena, CA, 91109-8099

Abstract — We have developed the first membrane-compatible Transmit/Receive (T/R) module (T/R membrane). Using these modules we developed a membrane-based active phased array in L-band (1.26GHz). We use phase shifters within each T/R module for electronic beam steering. In this paper we will discuss the T/R membrane design and integration with the membrane. We will also present transmit and receive beam-steering results for the array.

I. INTRODUCTION

Future very large interferometric Synthetic Aperture Radars (SAR) placed in high orbits will provide the measurements necessary to enable modeling of earthquakes and eventually earthquake forecasting in a twenty-year time frame [1]. The requirement for fine temporal sampling, and therefore, for short orbit repeat periods, is a major driver in the architecture of these systems. Compared to low orbit systems, Medium or Geosynchronous Earth Orbit (MEO or GEO) SAR systems with 2-D beam-steering capability promise greatly improved Earth coverage and enable the required short revisit times. However, these architectures place greater demands on the instrument; perhaps the greatest technological challenge with operating in these orbits is the size of the antenna. For a MEO system the antenna will have an area of 400m^2 and a GEO system will need a phased array of about 700m^2 [2]. Conventional phased-array antenna technologies with a mass density of $8\text{-}15\text{kg/m}^2$ (for antenna, electronics and structure) will not meet the goals of these future space-based SAR missions due to their large mass, stow volume and cost [3]. Existing launch vehicles are not capable of supporting the payload requirements of such an antenna. Current systems use rigid manifolds where electronic components are individually packaged and integrated onto panels. One method to dramatically reduce the weight, stow volume and associated cost of space-based SAR is to replace the conventional rigid manifold antenna architecture with a flexible membrane. Using this approach we expect to achieve a mass density of 2kg/m^2 . To date, only passive membrane antennas are reported; Fig. 1 shows one of these arrays. These passive arrays were 3-layer structures, which are not compatible with integration of T/R modules [4]. This paper discusses the first active membrane array, utilizing integrated T/R membranes.

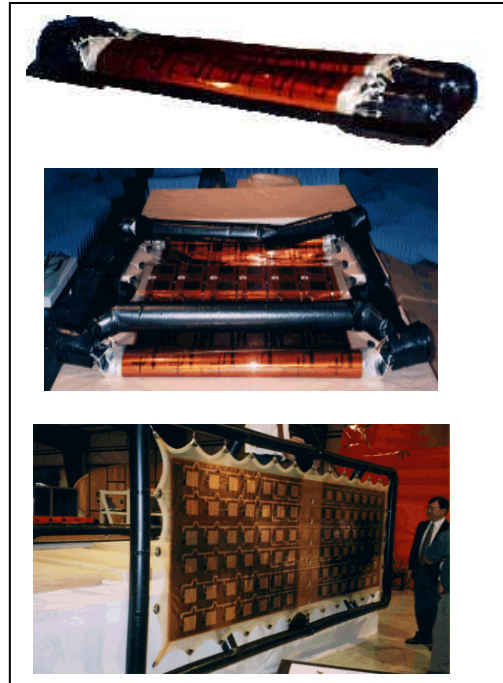

Fig. 1. JPL's 1x3m passive membrane antenna. The top figure shows the antenna in stowed configuration. The antenna is partially deployed in the middle figure. The fully deployed antenna is shown in the bottom.

II. ACTIVE MEMBRANE ARRAY ARCHITECTURE

The architecture of the active membrane phased array is shown in Fig. 2. Unlike previously reported 3-layer passive arrays, this array is composed of only 2 layers, with radiating patches on one layer and their ground plane on the second layer. Each patch of the array has a T/R module associated with it. The membrane is $50\text{-}\mu\text{m}$ -thick Pyralux®AP™ (Dupont's copper-clad all-Polyimide flexible circuit material) with $9\mu\text{m}$ copper layers. The T/R electronics, located on the backside of the ground plane, are coupled to the patches via slot feeds. The antenna feed detail is discussed in [5]. The T/R module for this work is a hybrid multi-layer module, also on a flexible substrate (Pyralux®AP™), that is assembled independently and attached to the membrane array.

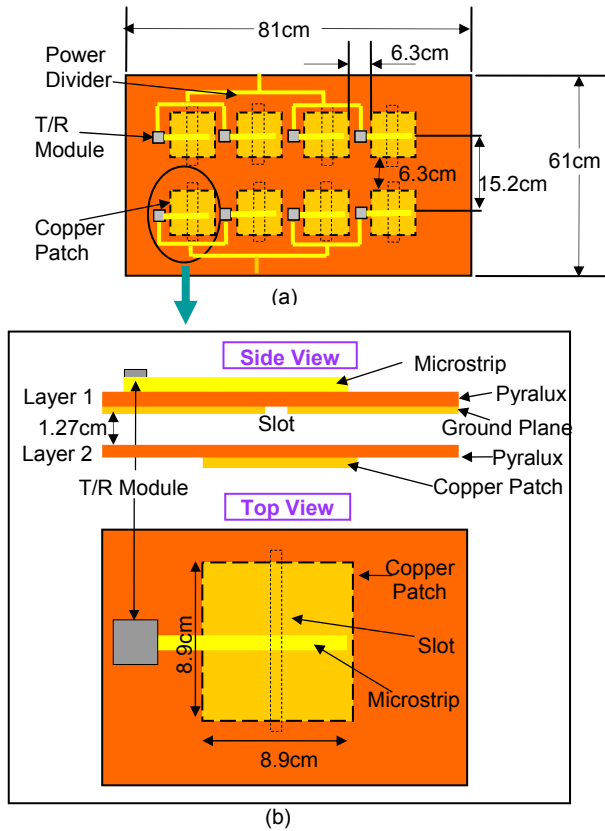

Fig. 2. Membrane antenna architecture. (a) 2x4 element array. (b) Unit cell top and side views.

III. TRANSMIT/RECEIVE MODULE

Conventional L-band T/R modules are bulky, packaged hybrid modules, which are bolted onto a rigid structure to make phased array panels; therefore, they are not physically compatible with membrane-based antennas. The first challenge of realizing an active membrane antenna is to develop a membrane-compatible T/R module. This requires developing RF circuits on flexible substrates, with a limited number of layers (to keep the circuit flexible) and with minimal or no package enclosure. Such requirements make RF circuits susceptible to unwanted coupling, interference and oscillations. In addition, this makes modeling of these circuits very difficult. Fig. 3a shows the simplified block diagram of our L-band T/R module. This proof-of-concept T/R module does not include the control electronics or biasing and telemetry circuitry that are common in space-based phased arrays. The module's transmit chain, shown in the top portion of the circuit, consists of a driver and a power amplifier (PA); and its receive chain, shown in the bottom portion of the circuit, consists of a low noise amplifier (LNA). Common to both chains are two switches, SW1 and SW2, which are used to enable transmit or receive modes. The RF isolation of the SW1 is critical to protect the LNA during transmit. The 6-bit phase shifter, common to transmit and receive, is used to steer the beam electrically.

The PA (MAAPGM0036) is capable of 1.2W of peak power output, and requires a driver amplifier (MAAPGM0026) for our application. The LNA (MAAM12000) has a noise figure of 1.6dB and a gain of 26dB. The switch (SW90-0002) is a single pole double throw (SPDT) switch, and the phase shifter (MAPCGM0001) is a 6-bit phase shifter with parallel TLL controls. All these parts are M/A-com GaAs MMIC's.

Fig. 3b shows the membrane compatible T/R module. In order to achieve low profile and mechanically flexible T/R modules, we built the T/R modules on Pyralux®AP™ flexible membrane substrates. We used surface mount packaged parts as a first step to a fully integrated, flexible T/R module. In order to preserve flexibility, however, we did not package the assemblies into a module level enclosure.

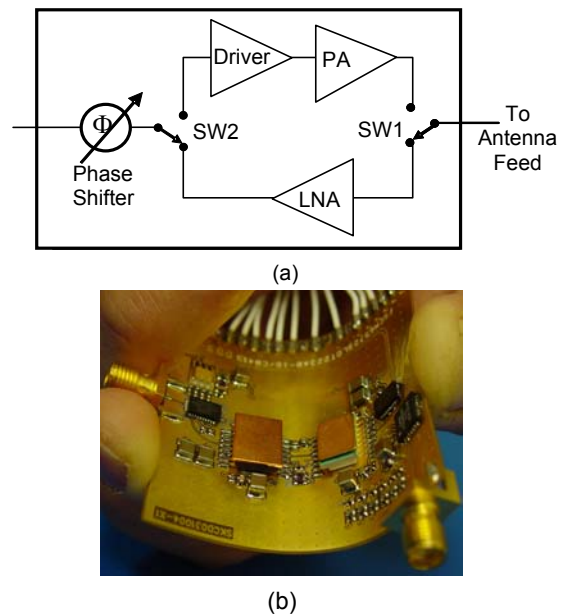

Fig. 3. (a) Block diagram of T/R module. (b) Photograph of the flexible membrane T/R module.

We built the first few iterations on 2-metal-layer substrates (front and back copper layers on a single dielectric), using a 50 μ m Pyralux®AP™ board with 9 μ m metal layers on each side. All of these modules suffered from oscillations. Due to the high gain of the loop formed by the transmitter and receiver path, the T/R module can easily become unstable. The key to achieving stability is to isolate the transmit chain from the receive chain and suppress unwanted coupling and RF "sneak paths". Components can be selected to provide the isolation required within the primary RF paths, but suppressing unwanted paths is more difficult. In traditional T/R module designs segmenting the package into small cavities with cover plates suppresses unwanted coupling modes. Since the flexible design cannot have a package over the entire module, our only option for suppressing unwanted coupling is careful circuit layout. We suppressed many of these oscillations by layout changes; however, the circuit was

still sensitive and susceptible to bias-line induced oscillations. We observed these stability problems in the receive path, possibly due to the high gain of the LNA. We ultimately overcame this problem by using a 3-metal-layer flexible board. In this design, the RF circuit is on a 50 μ m substrate and the DC bias lines are on a 25 μ m substrate that is separated from the RF circuit by a 9 μ m copper layer, which acts as a shield between the RF and DC. Although these modifications yielded a slightly thicker substrate, the new design was stable and the assembled module was only slightly less flexible. For the membrane T/R module shown in Fig. 3b, we measured a receive-gain of about 17dB and transmit-gain of about 30dB at its center frequency of 1.26GHz, Fig. 4. The T/R module has gain flatness better than 0.5dB and phase flatness better than 1 $^\circ$ for both transmit and receive within the useable bandwidth of 80MHz.

It is worth noting that we are currently using the minimum available Pyralux®APT™ copper thickness for all T/R modules and antennas fabricated. Although there is a thinner (25 μ m) dielectric Pyralux®APT™ available, we selected the 50 μ m material because the dielectric constant of the material dictates a 100 μ m line width in order to obtain a 50 Ω RF line on the 50 μ m thick material. Use of the thinner 25 μ m material would reduce line widths to 50 μ m, drastically increasing fabrication difficulty and reducing product reliability.

IV. ARRAY CONSTRUCTION

We used the above mentioned T/R membrane for the construction of an 8-element active array. Before integrating the T/R modules with the antenna, which was discussed in section II, we tested each individual module. The gain variation of the T/R modules was about ± 1 dB for receive and more than ± 2 dB for transmit. Fig. 5 shows the 2x4 element antenna in its stretched configuration. The picture is taken from the side showing layer 1. Tension springs connected between the edges of the antenna's catenary-shaped boundary and the metal frame keep the antenna taut and flat. Fig. 6 shows the partially rolled antenna. The ability to roll will allow the future very large space-based membrane antennas to be stowed for launch.

Fig. 7 is a close-up of layer 1 of the array (Fig. 5). The figure shows 4 T/R modules and the microstrip lines connecting the T/R modules to the antenna feeds. The feed is a slot etched in the ground plane located on the back-side of the layer. The feed is visible through the 50 μ m-thick Pyralux®APT™, which is thin and therefore transparent. Two 4-way power dividers are used to carry RF signals to/from the T/R modules located on the top and bottom of the array. Fig. 7 shows half of each of these dividers. The DC and control lines feeding the 4 T/R modules are also shown in the figure. These lines are located on front- and back-sides of layer 1 with copper-plated vias connecting the two sides. Alignment of the slot-feed to the radiating patch is critical for

feeding the signal to/from the antenna. We used alignment holes on the layers of the antenna for optically aligning the feeds with the patches. Some of these alignment holes are labeled in Fig. 7.

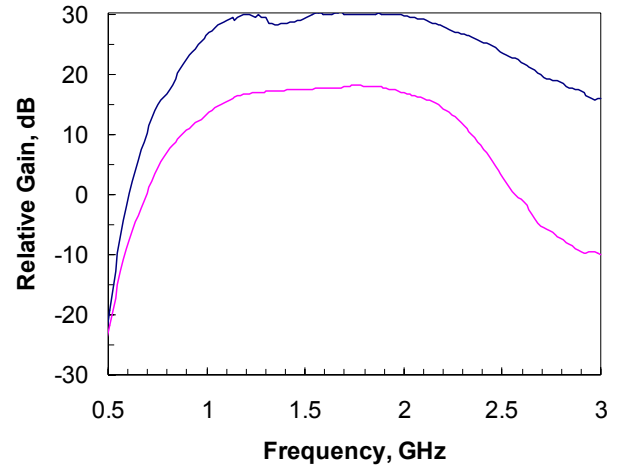

Fig. 4. T/R module gain in transmit and receive.

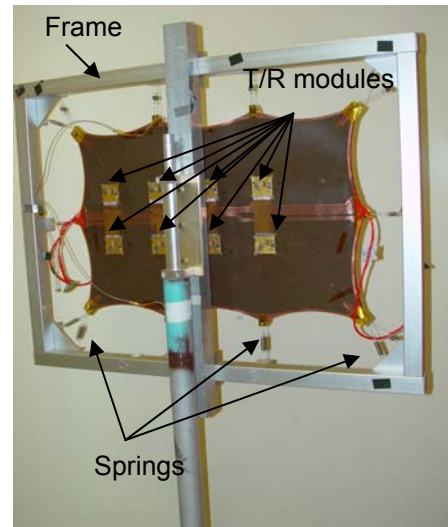

Fig. 5. Layer 1 of the array, defined in Fig. 2.

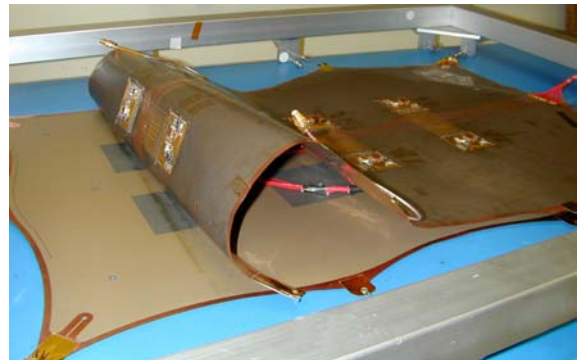

Fig. 6. Antenna in rolled configuration

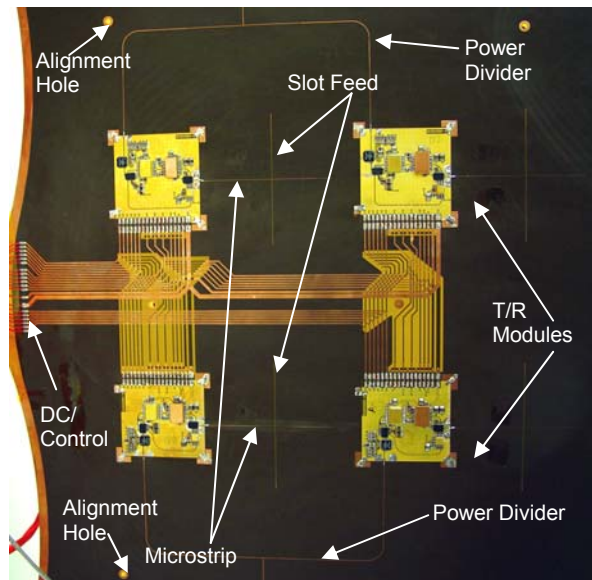

Fig. 7. A close-up of the array showing four of the T/R modules.

V. MEASURED RESULTS

We tested this active phased array at our antenna range. We adjusted the phase of the phase shifters in the array to achieve beam steering. We did not adjust the phase-shifter values to account for variability between the different T/R modules. Figures 8 and 9 show the measured and theoretical patterns for 0° and 15° steering angles in receive and transmit modes, respectively. The theoretical pattern assumes equalized T/R module gains. Cross-polarization patterns, which are not shown, are better than -30dB , for all cases. As expected, for a small array the sidelobes were high at angles beyond 30° (not shown in the figure). As discussed in section IV the amplitude imbalance of the T/R modules is more pronounced in transmit. This contributes to the discrepancy between the measured and theoretical values of the transmit pattern shown in Fig. 9. Nevertheless, for all cases the main beam steered to its expected scan angle. Future designs will include a programmable attenuator for equalizing the imbalances of the T/R modules.

VI. CONCLUSION

We demonstrated the first 2×4 element active array using membrane technology. We developed membrane-compatible T/R modules and integrated them with the membrane array. We demonstrated electronic beam steering using this membrane antenna. The next step in the development of T/R membranes is to integrate the digital control electronics with the T/R module. In addition we need to develop technologies for larger arrays.

ACKNOWLEDGMENT

The research described in this paper was carried out at the Jet Propulsion Laboratory, California Institute of Technology, under a contract with the National Aeronautics and Space Administration.

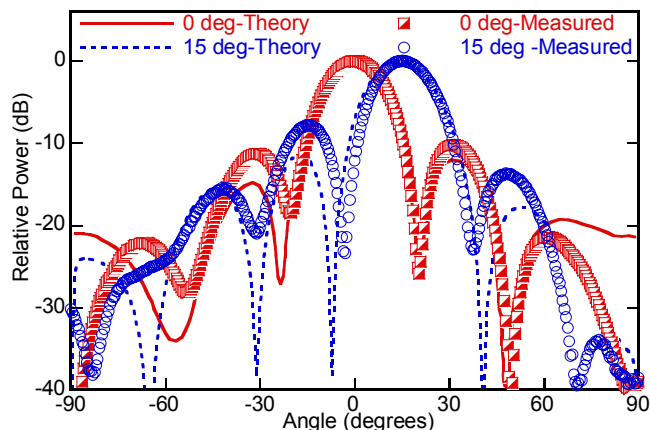

Fig. 8. Receive antenna patterns for 0° and 15° steering angles.

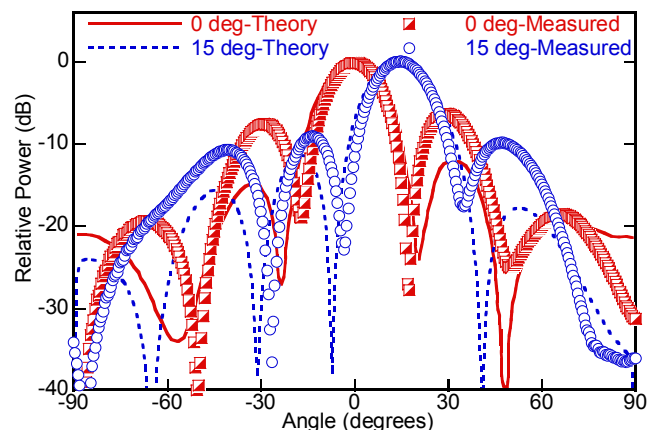

Fig. 9. Transmit antenna patterns for 0° and 15° steering angles.

REFERENCES

- [1] S.N. Madsen, C. Chen, and W. Edelstein, "Radar options for global earthquake monitoring," *IEEE Symposium on Geoscience and Remote Sensing, IGARSS '02*, July, 2002.
- [2] C. W. Chen, A. Moussessian, "MEO SAR system concepts and technologies for Earth remote sensing," *AIAA Space Conference*, September 2004.
- [3] W. Edelstein, S. Madsen, A. Moussessian, C. Chen, "Concepts and technologies for Synthetic Aperture Radar from MEO and Geosynchronous orbits," *SPIE International Asia-Pacific Symposium, Remote Sensing of the Atmosphere, Environment, and Space*, November 2004, Honolulu, Hawaii USA.
- [4] Huang, Lou, Feria, and Kim, "An inflatable L-band microstrip SAR array," *IEEE AP-S/URSI Symposium*, Atlanta, GA, June 1998, pp. 2100-2103.
- [5] J. Huang and A. Moussessian, "Thin-membrane aperture-coupled L-band patch antenna," *IEEE AP-S/URSI Symposium*, Monterey, CA, June 2004.