

# APPLICATION OF APS ARRAYS TO STAR AND FEATURE TRACKING SYSTEMS

Christopher Clark, Orly Yadid-Pecht, Eric Fossum, Phil Salomon and Ed Dennison  
Jet Propulsion Laboratory, California Institute of Technology  
Pasadena, (A 91109)

## ABSTRACT

Reducing mass and power demands from engineering and science image sensors, while improving system capability, remains a driving force in the development of Sciencecraft components. The Jet Propulsion Lab (JPL) is developing advanced concepts for future spacecraft celestial trackers by incorporating active pixel sensor (APS) array technology into star and feature tracker designs. We describe fundamental APS array properties and characteristics, and discuss recent progress in APS designs directly applicable to next generation trackers. A description of a new regional electronic shutter design providing extremely high dynamic range and local shuttering capability is given along with test results from a prototype device. A new star and feature tracker concept enabled by this regional shuttering capability is described.

**Keywords:** active pixel sensors, trackers, regional shutter.

## 1. INTRODUCTION

Spacecraft rely on star trackers to help determine attitude and pointing so that on-board instruments are properly aligned with their targets. Traditionally, star trackers have been relatively massive and power hungry and limited to star tracking. More recently lower mass and power star tracker designs have emerged. The goals of the New Millennium Program (NMP) Sciencecraft call for reduced mass and power budgets over present tracker designs, and generally, smaller and smarter spacecraft with autonomous capabilities. Specifically, it is highly desirable and cost efficient for NMP spacecraft to be capable of autonomous navigation and data collection using small, low-mass systems.

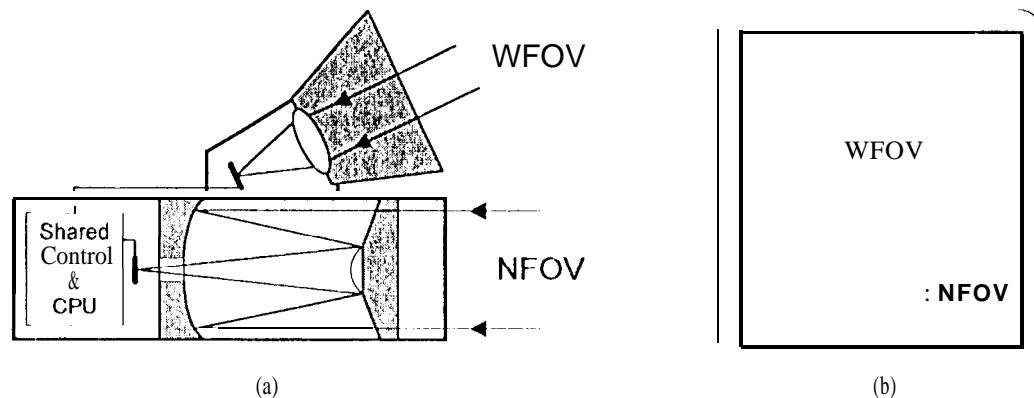
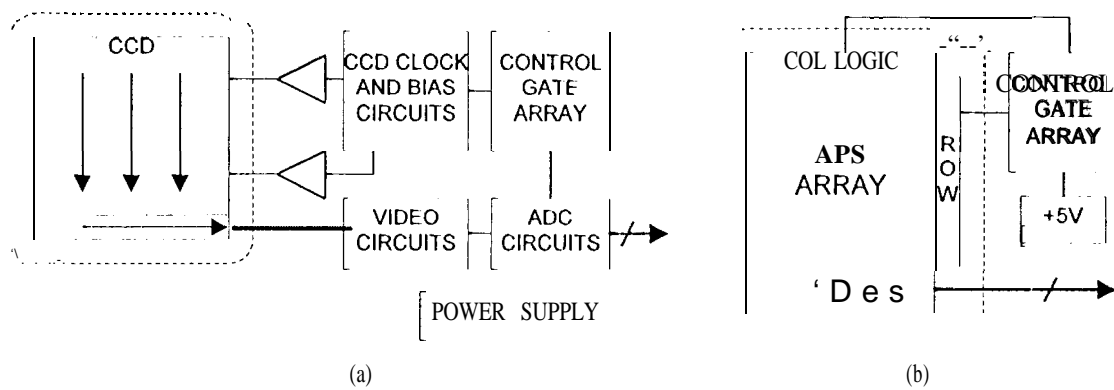

**Figure 1. A compact and powerful star and feature tracking system is created by combining a narrow field of view (NFOV) science camera and a wide field of view (WFOV) star tracker. Both instruments use APS imaging arrays, share common electronics (a), and are optically co-aligned to observe a common region in the pointing direction (b).**

To meet these goals, a new generation of star and feature tracking instrument concepts are being developed at JPL. One such tracker concept is presented here, and utilizes both existing spacecraft instrumentation, (science cameras and trackers) and new image sensor technology to produce a system capable of autonomous navigation and data collection. At the heart of this system are APS arrays, a new image sensor being developed at JPL that provides enabling capabilities and power reductions critical to NMP needs. Recent advancements in APS technology, described here, are utilized in this new star and feature tracker design along with a co-aligned, common field of view (CFOV) concept.

## 2. APS IMAGING ARRAYS

APS arrays are based on a relatively simple idea that has only recently been realized in a working device. Fabricated using industry standard CMOS technology and methods, the APS array<sup>1,2,3</sup> is essentially an array of photo-sensors, each with a local amplifier plus row and column addressing capability. By selecting the address of a given photo-sensor, the collected photo-signal in that cell or pixel can be brought to the edge of the array for external sample. The key to the APS is the design and placement of an addressable, low-noise charge-to-voltage amplifier circuit within the boundary of each pixel. Addressing a given pixel is done by writing a digital word into a pixel select register on the APS array, much like addressing a conventional memory chip. In comparison, a charge-coupled device (CCD), typically used in conventional star trackers, requires an elaborate array clocking sequence to access a given pixel. Consequently, CCD pixel addressing requires external support electronics (figure 2) to generate complex clocking waveforms in the form of both digital logic levels, and analog CCD clocking voltages.



**Figure 2. CCD array control (a) requires a sizable collection of analog and digital support circuits. In comparison, APS arrays can be controlled with a minimum set of components (b) due to their extensive on-focal plane electronics. Reducing total camera electronics component count shrinks circuit board size, reduces failure risks, and decreases overall power consumption.**

The digital interface to APS control is not the only advantage it has over the CCD, as has been discussed elsewhere<sup>3,4</sup>. While both arrays ultimately produce analog, voltage levels reflecting the collected signal level in a given pixel, recent APS advancements<sup>5</sup> have demonstrated excellent on-chip analog-to-digital (ADC) converters, thus enabling a complete camera-on-a-chip concept. For the star tracker designer, this means that analog video processing and sampling circuits, often prone to circuit board noise contamination, can be placed on the APS chip itself, thereby reducing total chip count and eliminating potential noise problems. Further, it has been demonstrated<sup>5</sup> that a column-parallel ADC architecture can be successfully fabricated and operated. This architecture places a video sampling ADC circuit at the end of each APS column, thereby relaxing the conversion rate requirements on each ADC, which in-turn improves ADC accuracy and performance. Currently, on-chip column-parallel architecture ADCs have shown excellent accuracy ( $< 1\text{LSB DNL}$  and  $\text{INL}$ ), high conversion rates ( $> 100\text{kHz}$ ) and extremely low power operation ( $< 50\ \mu\text{W}/\text{ADC}$ ).

While CCD image sensors have achieved remarkable performance over the past 25 years, APS arrays are rapidly reaching competitive performance levels and, in some categories, even surpassing the CCD. Today, science grade APS arrays suitable for star trackers have been demonstrated with read noise floors below 15 electrons r.m.s, quantum efficiencies exceeding 60% (for photodiode-type APS), formats as large as  $1024 \times 1024$  pixels, and less than 1.5% overall gain non-uniformity. However, perhaps the most attractive feature of the APS for Spacecraft applications, is its ability to readily support on-focal plane electronics integration. As a result, it is now possible to produce complete camera-on-a-chip arrays suitable to both science and tracking needs, enabling small, low-mass packages that consume less than 100 mW of power.

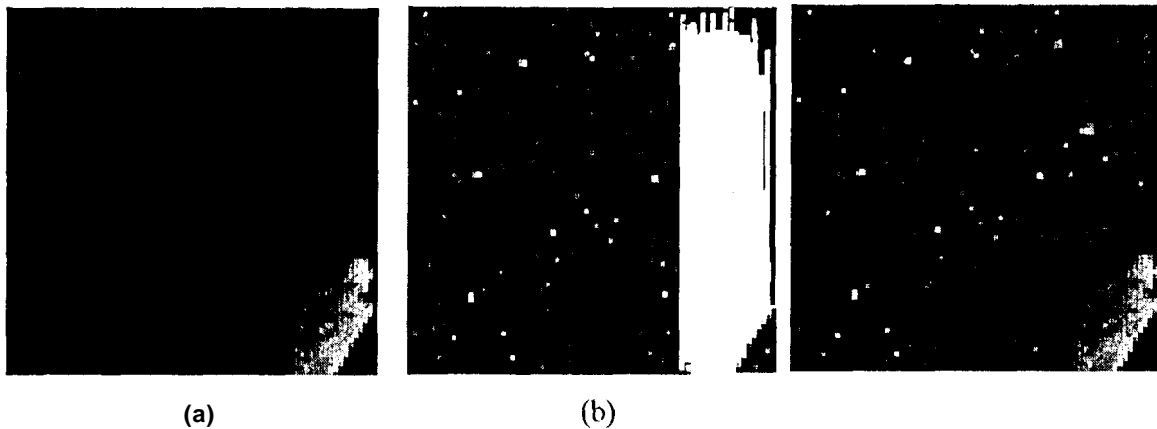

Figure 3. Application of a regional shutter concept to a simulated WFOV image containing both faint stars and a bright extended object. (a) Using a CCD, a short integration is required to properly record the extended object (bottom right) sacrificing background stars. (b) A sufficiently long integration brings out background stars but causes blooming across the image. (c) The APS regional shutter allows short integration times around the extended object and long integration for the stars.

### 3. REGIONAL ELECTRONIC SHUTTER

For many imaging applications, conventional imaging devices do not provide adequate dynamic range. For star and feature trackers, this can be the case when attempting to image relatively faint background stars along with a bright extended object in the same field of view (a fly-by mission for instance as shown in figure 3). The brightest objects may cause significant blooming across the image at saturation if some form of anti-blooming is not employed. More importantly, even if the blooming is suppressed, there exists a dual requirement to properly image the scene. Namely, a short exposure is required to properly image the bright object, while a longer integration is needed to record the fainter stars. Traditionally, this requires two separate exposures and post-processing to correlate them as the spacecraft pointing may drift between the two frames.

Recently, a regional electronic shutter concept for the APS<sup>6</sup> has been developed and implemented in a test device at JPL. In this APS design, an addition is made to the generic APS amplifier placed within each pixel that allows the independent reset of an addressed pixel. The test device built shows, as expected, excellent output signal linearity versus integration time over the entire dynamic range of the device. The electronic shutter linearity is very well behaved (see figure 4). Test results also show that this pixel reset method does not degrade read noise nor introduce any reset anomalies.

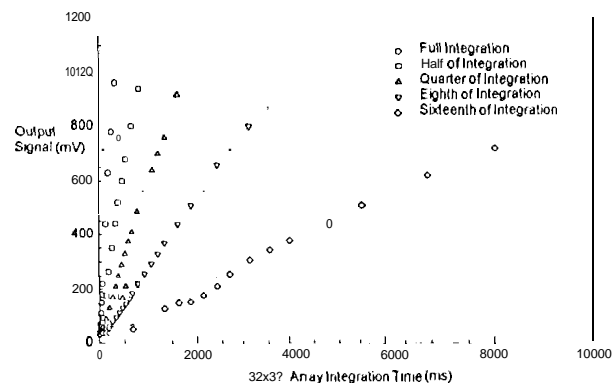

Figure 4. Regional shutter is quite linear in nature.

An added benefit of this individual pixel reset, over more traditional array-wide reset techniques, is the ability to perform non-destructive readouts<sup>7</sup>. This feature enables instruments to achieve optimal signal-to-noise without prior knowledge of the correct exposure time. By performing periodic non-destructive readouts over the course of an integration, it is possible for a CPU to monitor signal level and terminate the integration at the desired signal-to-noise. This ability enables a new level of autonomous image data collection that is extremely well suited to the needs of the proposed NMP Sciencecraft missions.

#### 4. STAR AND FEATURE TRACKER FOR AUTONOMOUS MISSIONS

Modern spacecraft star tracking systems have tended to shift toward WFOV optics in recent years. This is primarily due to advancements in star identification and tracking software that utilizes large samples of relatively bright stars to improve accuracy. As a result, one now finds trackers with small aperture optics producing images covering 20 to 40 degrees on a side becoming more common. This wide field of view is also quite useful for feature tracking when the spacecraft is sufficiently close to the target such that target features are resolved. The downside of this wide field of view approach is in its limited range of useful star magnitudes, typically stars brighter than magnitude 6 or 7 arc required, and its inability to resolve target features until the spacecraft is relatively close to an extended object (of course, required proximity scales with target size).

However, the combination of a WFOV tracker and a NFOV science camera, often flown on NASA missions, along with support software and a CPU, creates a powerful and compact system capable of autonomous navigation and data acquisition. In this design concept, shown earlier in figure 1, a WFOV tracker is co-aligned with a NFOV science camera such that a subset of the NFOV is imaged by the WFOV camera. An image based on this design has been simulated in figure 4. Sharing this common FOV offers several advantages. First, a shared FOV provides a means of calibrating both instrument's boresight over the course of the mission. Secondly, the NFOV can acquire navigational bearings from parallax measurements of asteroids too faint for the WFOV to image, while the WFOV provides the general pointing to the asteroid field. Finally, the WFOV and NFOV combination compliment feature tracking needs over much more of the mission than either camera system alone can support.

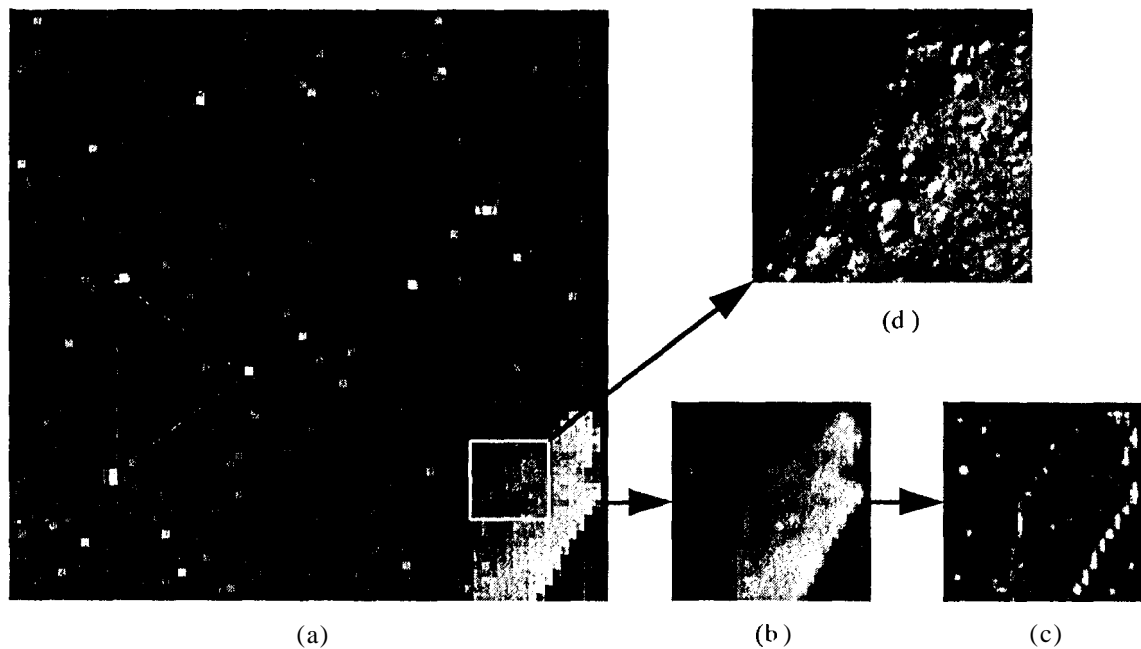

**Figure 5. Combining a WFOV tracker with a NFOV science camera produces a powerful star and feature tracking system. (a) The WFOV system uses regional shuttering to track background stars and image extended objects. The extended object sub-image is processed (b) to allow feature tracking (c) used to point the NFOV science camera. The NFOV science camera (d) is free to collect data without the overhead of tracking responsibilities.**

Adding the regional electronic shutter to the WFOV creates an even more powerful system capability. This addition provides a means of acquiring both background stars and target information with the WFOV during highly time-critical science data acquisition sequences. During an asteroid fly-by, for instance, it is desirable to rapidly acquire science data during the brief optimum conditions and distances.

However, if the asteroid has not previously been observed in great detail, exact pointing and sequencing for optimum data acquisition will not be known in advance. Thus, to operate in a completely autonomous mode, the spacecraft must decide for itself what are the most interesting science target opportunities and how to properly sequence the data acquisition cycle. For the system design described in this paper, during science data acquisition, the WFOV tracker provides the ability to track features on the target, feeding critical feature location and viewing information into the spacecraft control and scheduling system, while maintaining a navigational watch on background stars. Meanwhile the NFOV is free to acquire data at its maximum rate, not burdened by navigation and pointing duties. This combination of the WFOV tracker and NFOV science cameras creates an efficient instrument capable of supporting a wide range of autonomous navigation, tracking and data collection needs, and is complimentary to the goals of the NMP Spacecraft concept.

## 5. SUMMARY

APS arrays have matured rapidly and now offer a wide range of capabilities that will lead to trackers with reduced power consumption, simplified and improved electronic layout options, and increased capability. On-chip ADC circuits directly lead to reduced chip count and simplified electronics layout within the tracker electronics unit. Regional shuttering capability dramatically increased the effective dynamic range of trackers and enables a means for optimizing image signal-to-noise level in real-time. A combined WFOV tracker and NFOV science camera system has been described that supports autonomous spacecraft missions proposed by the NMP.

## 6. ACKNOWLEDGMENTS

This work was carried out at the Jet Propulsion Laboratory, California Institute of Technology, and was sponsored by the National Aeronautics and Space Administration. We are grateful to C. Staller for valuable discussion on APS operation and test techniques. We also wish to thank G. Udomkesmalee, R. Blue, A. Eisenman, J. Alexander and R. Bartman for valuable discussion on this tracker concept.

## 7. REFERENCES

1. R. H. Nixon, et al, "256x256 CMOS Active Pixel Sensor Camera On A Chip", pp. 178-179, Proc. IEEE International Solid-State Circuits Conference, San Francisco, Ca. Feb. (1996).
2. S. Mendis, S.E. Kemeny, R. Gee, B. P'sin, and E.R. Fossum, "1 $\sigma$  Regress in CMOS Active Pixel Image Sensors", in CCDs and Optical Sensors IV, Proc. SPIE vol. 2172, pp. 19-29, (1994).
3. E.R. Fossum, "Active Pixel Sensors - are CCDs Dinosaurs?", Proc. SPIE, Vol 1900, pp. 2-14, (1993).
4. E.R. Fossum, R.K. Bartman, and A. Eisenman, "Application of the active pixel sensor concept to guidance and navigation", in Space Guidance, Control, and Tracking, Proc. SPIE vol. 1949, pp. 256-265 (1993).
5. Zhou, B. Pain, R. Panicacci, B. Mansoorian, J. Nakamura, and E.F. Fossum, "Recent Progress In On-focal Plane ADC's", In Infrared Readout Electronics 111, Proc. SPIE Vol. 2745, Orlando, FL, April (1996).
- 6.0. Yadid-Pecht, C. Clark, D. P'sin, C. Staller, and E.R. Fossum, "Wide dynamic range APS star tracker", in Solid State Sensor Arrays and CCD Cameras, Proc. SPIE vol. 2654, pp. 82-92, (1996).
- 7.0. Yadid-Pecht, "The Automatic Wide Dynamic Range Sensor", in 1993 SHD Intl. Symp., Seattle, Washington, pp. 49 S-498 (1993).