

SIM Configuration Trades

Kim M. Aaron^a, William H. Mateer II, Richard L. Baron

California Institute of Technology
Jet Propulsion Laboratory

ABSTRACT

The Space Interferometry Mission (SIM) will perform astrometry to a resolution of a few micro arc seconds (after post-processing on the ground of the acquired data). The development of this mission is being led by the California Institute of Technology, Jet Propulsion Laboratory (JPL) for the National Aeronautics and Space Administration (NASA). A recent trade study was performed to compare two significantly different architectures. This paper will describe the two configurations and contrast some of their differences and similarities.

Keywords: Classic, SIM, Space Interferometry, SOS, JPL, astrometry

1. SIM OVERVIEW AND SUMMARY

The prime science objective of the Space Interferometry Mission (SIM) is to perform very precise astrometric measurements of celestial objects over a five-year period. The required accuracy of these measurements is about $4\mu\text{as}$ (micro arc second) following post-processing on the ground. A key secondary objective is to use the interferometer to perform synthetic imaging.

1.1 Michelson Interferometer

The basic approach adopted is to form a Michelson interferometer using a pair of optics, each with a clear aperture of 33cm, separated by a baseline of about 10 m roughly perpendicular to the line of sight of the instrument. The starlight from the two arms of the interferometer are combined onto a detector. An Optical Path Delay (OPD) mechanism adjusts the pathlength in one or both arms of the interferometer until white light fringes are obtained on this beam combiner detector. At this point, the two paths from the star through the optics to the detector are equal in length. By accurately measuring the relative delay within the instrument itself, one can use trigonometry to deduce the angle between the incoming starlight and the baseline vector running between the two sets of collector optics.

Since an interferometer can only measure angles in a plane containing the baseline, in effect each observation provides one angular coordinate on the celestial sphere. It is necessary to observe each target with two roughly orthogonal orientations of the baseline in order to determine the position of the target. This implicitly assumes one knows the orientation of the baseline itself. However, determining the orientation of the baseline to an accuracy somewhat better than $4\mu\text{as}$ is quite a challenge. In fact, it is precisely the method used to accomplish this feat that distinguishes the two architectures under consideration here. This point will be discussed in some detail below.

1.2 Fiducials and the Baseline

The term, "baseline" has two related but distinct meanings. Two parallel tubes of light coming from the target star are collected by primary mirrors. These two tubes of light are then manipulated by several successive optics (mostly reflective; there is one beam splitter) in such a way that the tubes are combined on

^a Author e-mail addresses:

a detector. In SIM (either architecture) the tubes of collected light have a diameter of 33 cm and by the time they reach the detector they have a diameter of 3 cm. Starting at a single point on the detector and tracing a single ray back out through the system, it will split into two rays, one for each arm. Outside of the interferometer, these two rays should be parallel if the optics are aligned correctly. The perpendicular (minimum) distance between these two incoming rays is the astrometric baseline. For perfect optics, the astrometric baseline would be the same for all points on the detector.

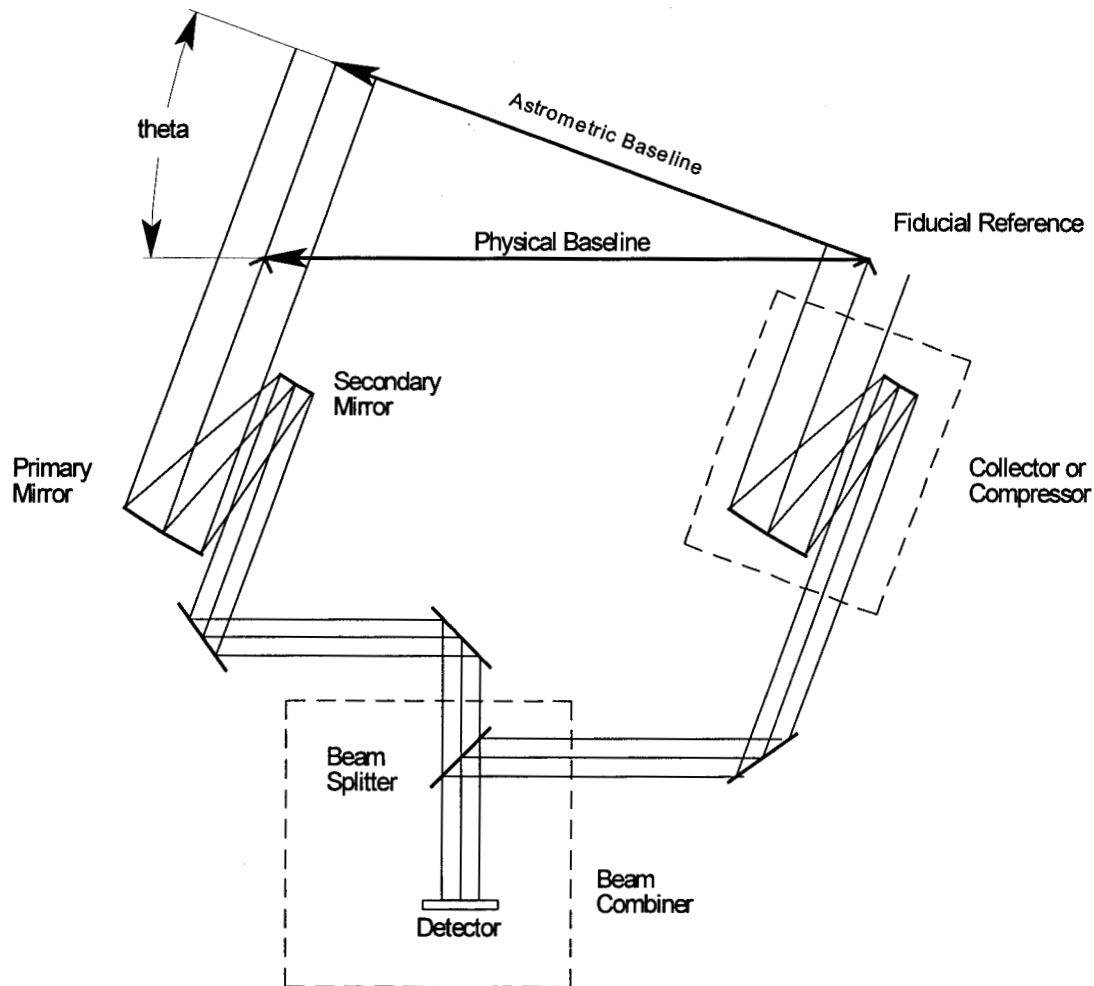

Figure 1 Schematic defining Physical and Astrometric Baselines

In SIM (both architectures), a reference point, or fiducial, is installed in the field of view of each collector. On SOS, this fiducial is suspended in front of the collector as shown in Fig 1. On SOS, the collector moves to change the line of sight. On classic, the fiducial is physically mounted on the surface of the siderostat mirror (shown in Fig. 4) which aims the line of sight of the collector. Both designs use retro-reflecting corner cubes as the fiducial, although other choices have been considered, such as hemispherical mirrors.

Various auxiliary cameras, detectors and beacons are used to actively control the positions of various optical elements in the light train to keep the fiducial in the center of the field of view of each collector, and also to ensure that a hypothetical incoming ray passing through the fiducials would end up at the same point on the beam combiner detector. Again assuming ideal optics, the field of view from each arm of the interferometer will be coincident on the detector and all points will have the same astrometric baseline.

Since we rely on the active control to maintain the alignment of the two optical trains on the two fiducials, we can measure the physical distance between the two fiducials to infer the astrometric baseline. The physical baseline is the vector connecting one fiducial to the other. Usually, this vector will not be perpendicular to the incoming starlight, but this angle is precisely what is measured by the interferometer, so the astrometric baseline is simply the physical baseline multiplied by the cosine of the angle between the starlight and the normal to the physical baseline :

$$\text{Astrometric Baseline} = \text{Physical Baseline} \times \cos(\theta).$$

1.2 Imaging using an interferometer

The discussion so far has implicitly assumed the targets are point sources. There are, of course, extended objects in the sky and it is of considerable interest to use an interferometer such as SIM to investigate these objects. Although an interferometer is not inherently an imaging system, it is possible to construct an image by taking measurements of the extended object with many different baselines (both length and orientation). This is exactly the same technique referred to as synthetic aperture imaging which has been used in radio astrometry (very long baseline interferometry, VLBI). Ground based optical telescopes have also been combined to form interferometers. The resolution of the resultant image is equivalent to a giant telescope with a diameter approximately equal to the maximum baseline of the interferometer used. The photon collecting area is of course much less since the aperture is very sparsely filled, so the time involved to create an image is much longer than would be required with the hypothetical giant telescope. Also, there is significant computation involved to create these artificial images.

1.3 The Fourier Plane

When one creates artificial images using an interferometer, each measurement corresponds to a point in the Fourier plane corresponding to the two dimensional Fourier transform of the image. The angle of the baseline vector determines the angle to the point in the Fourier plane. The length of the baseline determines the radial distance to the point in the Fourier plane. The amplitude plotted at this point corresponds to the signal from the interferometer (both magnitude and phase are required). After sufficient points have been measured in the Fourier plane, the inverse Fourier transform can be taken to create the corresponding artificial image. The Fourier plane is often referred to as the u-v plane since the coordinates axes are labeled u and v.

Points in the u-v plane acquired using a large baseline correspond to features in the image with a high spatial frequency. Distributed objects will have features at longer spatial wavelengths corresponding to shorter interferometric baselines. Point sources, such as stars at great distances, do not contain information at long wavelengths and so are best resolved by longer baselines. As the u-v plane is filled in with more and more points, the resultant image quality improves. It is thus desirable to be able to achieve short baselines as well as long ones. The longer baselines provide information about the location of point sources and the shorter baselines fill in the distributed portion of an image. Baselines are desired at several intermediate baselines to fill in the u-v plane more or less uniformly out to the radius corresponding to the maximum baseline. Although this imaging capability is a secondary objective of the mission, it is still considered very important and in fact was an important consideration in the trade-off between the two architectures.

1.4 The Reference Grid

One of the uses of a space-based interferometer with such fine resolution is to develop a star catalog with much better accuracy than previous catalogs. In fact SIM itself needs this catalog in order to have reference stars from which to make small offset measurements to dim science targets. One of the first activities of SIM will be to "close the grid." That is, SIM will acquire relative angular measurements for many many relatively bright stars around the entire celestial sphere. Eventually, when all these relative measurements are linked together, each of the measurements of these stars will then be refined to reduce the uncertainties in all of the measurements. The collective measurement will permit additional refinement of estimates of various geometric parameters that characterize the performance of SIM. In a sense, SIM will be self-

calibrating through the closing of the grid of reference stars. This process will be repeated several times throughout the nominally five-year mission.

1.5 Determining the orientation of the baseline

There are no existing star camera type attitude determination sensors that can establish the orientation of a space system to the accuracy that SIM will be able to resolve angles. The approach used by SIM is to add two more essentially identical interferometers to the main science interferometer. These will be used in conjunction to determine the attitude of the baseline. Basically, each of these "guide interferometers" will lock onto a nearby bright reference star. Since the locations of these grid stars will have been previously determined as part of the grid closure campaign, they will permit the orientation of the baseline vector to be determined very precisely.

The two architectures implements the extra guide interferometers differently. This difference is one of the aspects considered in the tradeoff.

2. SIM CLASSIC DESCRIPTION

SIM Classic is the name given to the "incumbent" configuration at the time of the trade study. Like any other configuration, it too went through many changes and in fact changed during the study as a result of the increased scrutiny experienced by both configurations at that time.

2.1 SIM Classic Configuration Description

SIM Classic is configured as a Tee-shaped structure when deployed. Along the arms of the tee are distributed seven collector bays (or siderostat bays). Within each bay is a fixed 11:1 compressor comprised of a 33 cm diameter clear aperture primary mirror and a 3 cm secondary. The mirrors are off-axis confocal paraboloids. Parallel star light entering the compressor exits parallel but compressed down to a 3 cm diameter bundle. These compressor assemblies are essentially fixed in the geometry of the layout. Facing each compressor is a gimballed flat siderostat mirror which serves to aim the system at targets of interest. The range of motion of the siderostats is $\pm 4.75^\circ$ corresponding to a motion of the line of sight of $\pm 7.5^\circ$. For a given space system attitude, any star within a 15° cone centered on the nominal line of sight can be selected. This cone is referred to as the field of regard (FOR). The actual field of view (FOV) is a few tens of milli arc seconds. Each of the seven siderostat bays is lined up with one another such that they all point nominally perpendicular to the arms of the tee. Thus, all seven share the same FOR. In the most recent incarnation, the center of this FOR was elevated up 30° from the top surface of the tee. For earlier layouts, this angle was 45° or 90° .

In the stem of the tee, there is a switchyard of mirrors which can select the starlight from any pair of collectors and direct the two beams onto any one of four beam combiners. Thus any pair of collectors can be used as an interferometer with baseline equal to the spacing between the two. The spacings of the seven assemblies along the tee were selected in such a way that no two combinations would yield the same baseline. The minimum baseline is about 0.4 m whereas the maximum is 10m. With seven elements, it is possible to form 21 different pairs, each with its own baseline length. These values are reasonably uniformly distributed between the minimum and maximum values so there are no substantial gaps in the u-v plane for imaging. Only three interferometers are needed to make a measurement.

ISOMETRIC VIEW

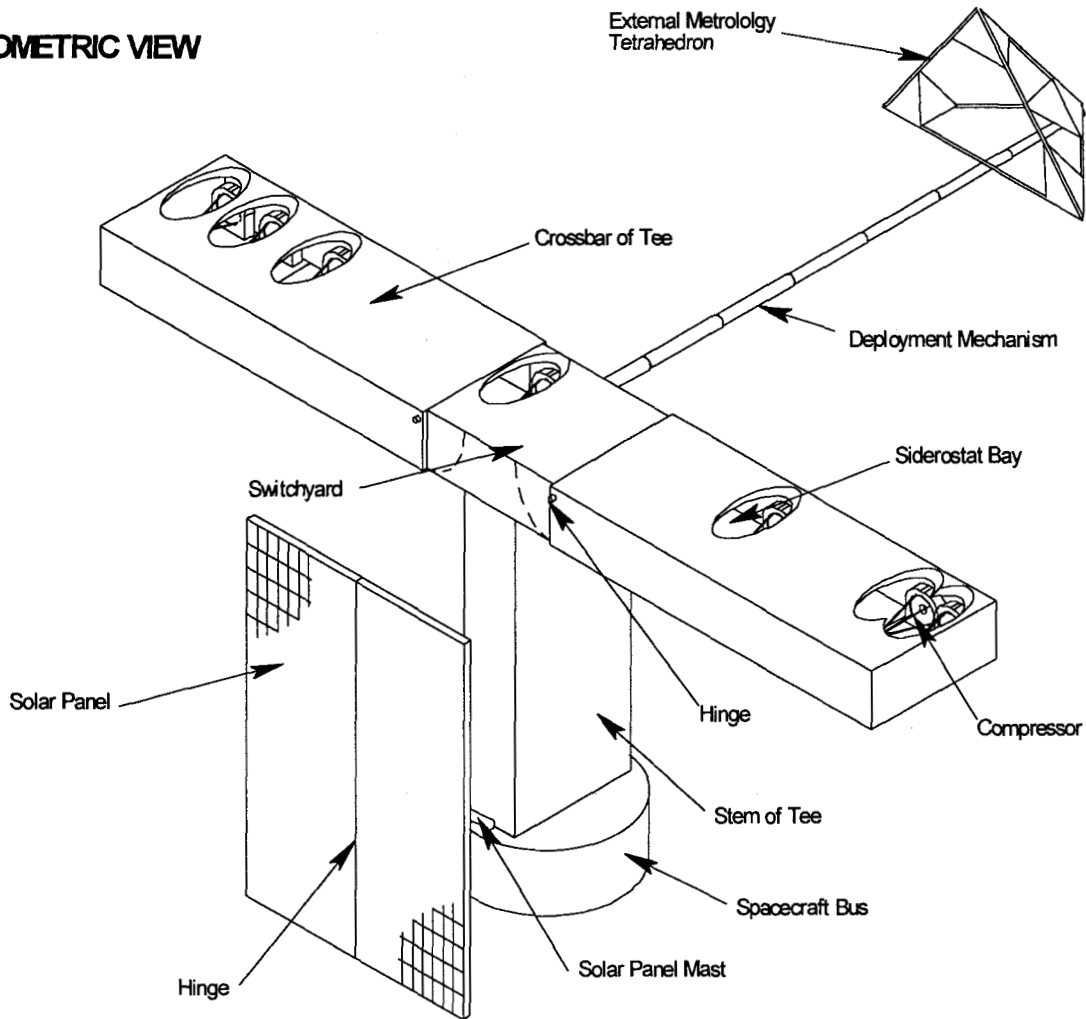

Figure 2 SIM Classic Deployed Configuration

For any particular observation, it is necessary to have three interferometers operating: two to act as guides and one to measure the science target. With Classic, astrometric measurements of the science target are made using the maximum baseline to achieve the greatest precision. However, this implies that the guides must use smaller baselines. This geometric disadvantage is offset by the brightness of the guide stars and is not a great issue.

2.2 Aligning the Corner Cubes: External Metrology

The purpose of the guide interferometers is to establish the orientation of the science baseline. Since each of the guide interferometers has its own baseline, really the guides determine very precisely one angle from a well-known guide star to that baseline. In order to establish the required orientation of the science baseline, it is necessary to determine the relative orientations of the three baselines. This is accomplished by using the external metrology system. The system uses 28 interferometric laser gauges to measure the distances between the seven fiducials mounted on the siderostats and each of four fiducials mounted on a separate external metrology tetrahedron. In addition, there are six laser gauges to measure the distances between each of the vertices of the tetrahedron. Using all this geometric information, it is possible to solve for the orientation of the science baseline.

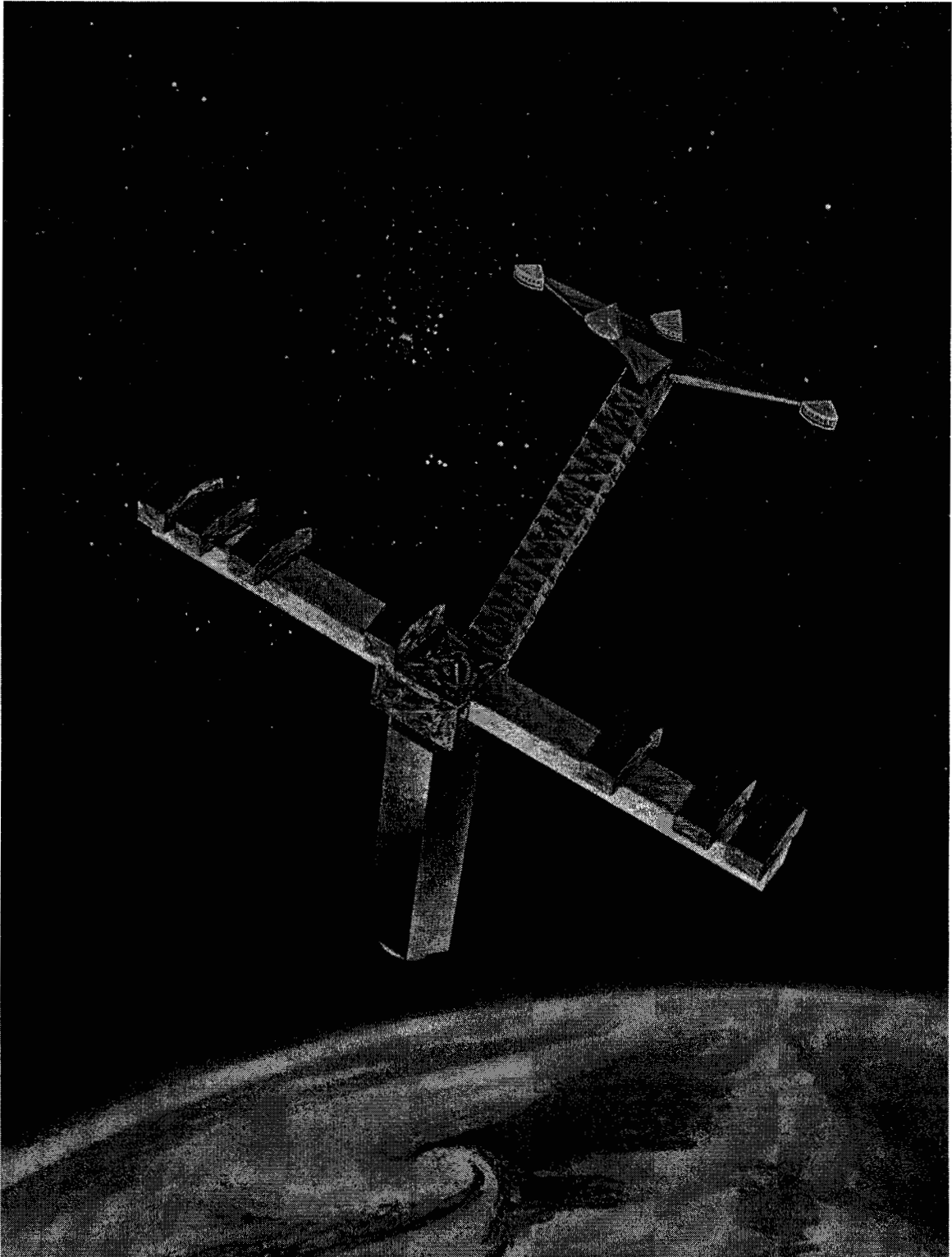

Figure 3 Artist's Concept of SIM Classic

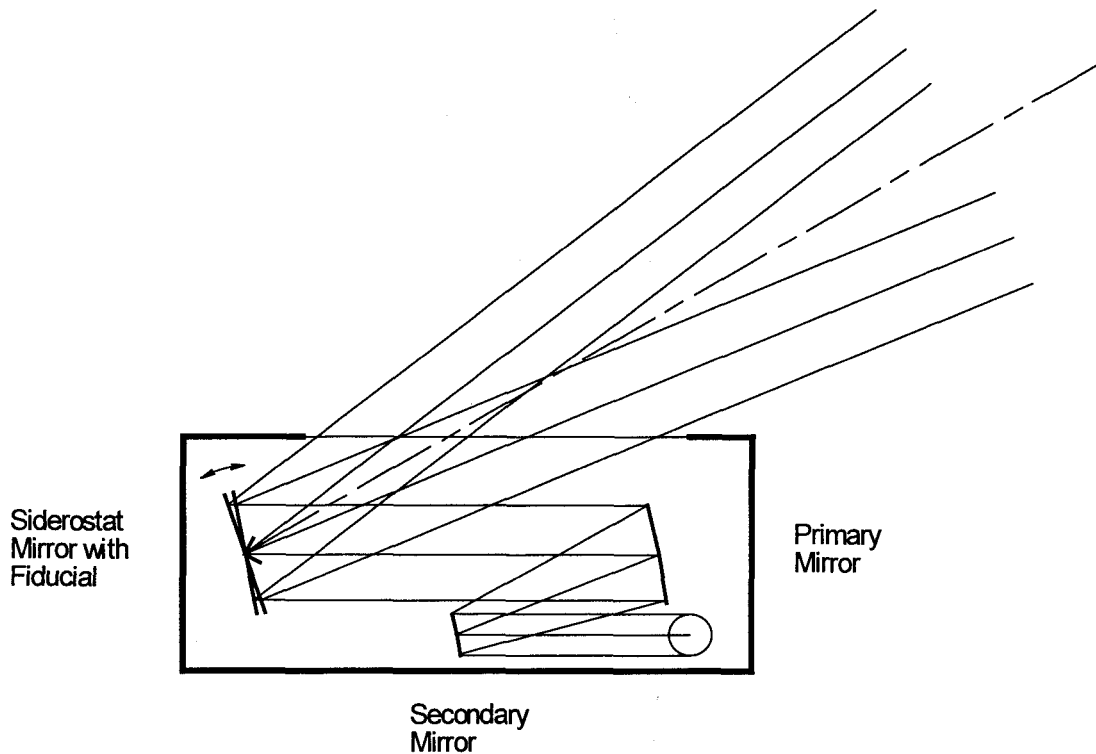

Figure 4 SIM Classic Siderostat Bay

3. SON OF SIM DESCRIPTION

Chronologically, the Son of SIM architecture followed SIM Classic. The key distinguishing factor between the two architectures is way in which the fiducials for the guide interferometers are related to the fiducials for the science (astrometric) interferometer. For SOS, there are only two fiducials and all collectors share the same fiducials. The same fiducials are used for both science and guide interferometers.

3.1 Son of SIM (SOS) Configuration Description

The Son of SIM configuration includes two collector pods, each of which houses four collector assemblies. Each collector is used in conjunction with an essentially identical collector in the other collector pod. In the current configuration, one of these pods is fixed, whereas the other moves on precise rails to vary the distance between the two pods. Alternative configurations have had two moving pods, and present work is leaning towards reverting to two moving pods. However, this is not an essential difference for purposes of comparing SIM Classic and SOS.

As stated earlier, only three interferometers are required: two to act as guide interferometers to establish the orientation of the physical baseline, and a third to measure the position of the science target with respect to that baseline. The fourth is included for redundancy. This extra interferometer is used primarily to achieve small baselines to satisfy the imaging objectives. However, this fourth interferometer will be adequate to perform the function of guide interferometer in the unlikely event that some unexpected failure should prevent one of the other three interferometers from working. Similarly, the nominal guide interferometers can also perform the function of the science interferometer.



Figure 5 Artist's Concept of Son of SIM

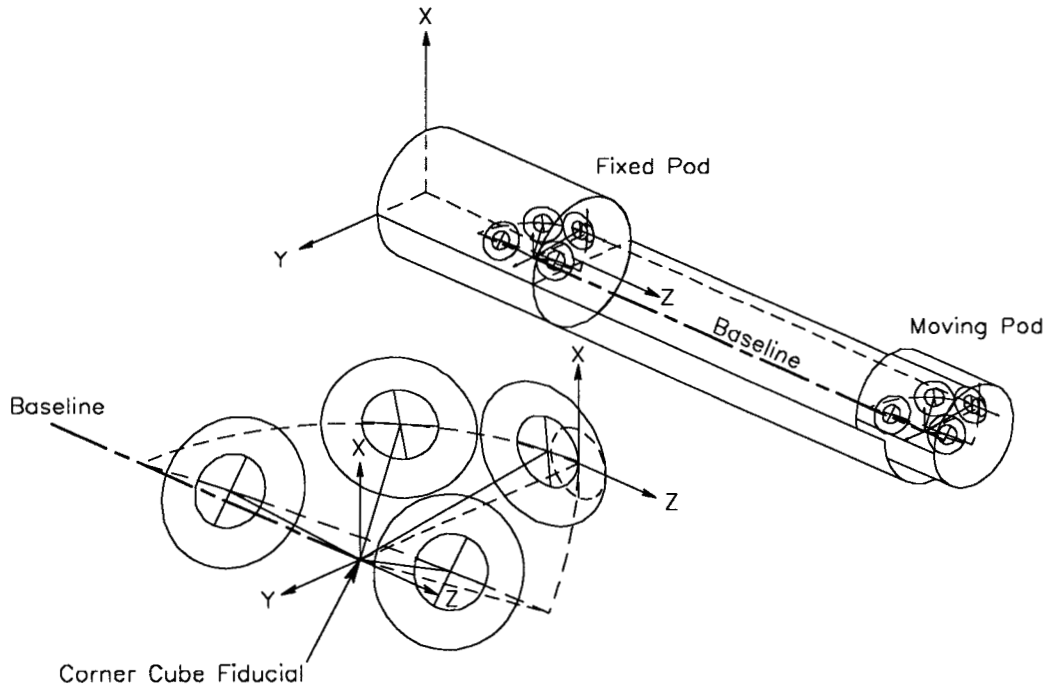

Figure 6 SOS Layout with enlarged view of collectors indicating their range of motion

As illustrated in Fig 6, since all four collectors share a common fiducial at the center of their fields of view, it is not possible for them to be pointed in the same direction, at least at the same time. Each collector

assembly is moved as a unit such that it remains tangent to a hypothetical spherical surface centered at the corner cube fiducial. The same field of regard is maintained (15° cone) as for Classic. In Fig.6 the four smaller circles represent the physical size of the mirror. The large circles represent the space covered by the mirrors as they move about their fields of regard. It can be seen that the collectors will not collide at the extremes of their motion. However, concepts have been investigated in which overlapping fields of regard have been allowed

3.2 Measuring the Baseline

Since all four interferometers share the same two fiducials, it is not necessary to have the external metrology tetrahedron that Classic has. Instead, a single interferometric laser gauge is used to measure the distance between the two corner cubes. This information, coupled with the knowledge of the angles between the two guide stars and the single baseline is sufficient to determine the baseline vector.

4. COMPARISON OF THE TWO ARCHITECTURES

In comparing two different architectures, it is difficult to separate the particular point designs from the inherent differences in the architecture. A comparison of two point designs may be invalid if the differences are due to essentially random particular implementation choices of the design team at the time. A true comparison of two architectures should focus on the inherent differences between the two architectures. This comparison validly should include implications about the ease of design associated with the choice, however.

In comparing SIM Classic and Son of SIM, the important difference between the two architectures is the fiducial defining the baselines. SOS inherently uses the same two fiducials for all four interferometers. Classic uses seven independent fiducials (only six are used at a given time). It is therefore necessary to add some means of measuring the relative orientations of the three separate baselines. This led to the external metrology tetrahedron (a particular design choice). The inherent difference in the architectures is the need to resolve the three baselines. This particular point was indeed the strongest discriminator that finally led to the selection of the SOS architecture over the Classic. There are, however, a host of other differences.

One such inherent difference between the two architectures is that for SOS, with four collectors sharing a single fiducial, it is not possible for the collectors to look the same direction at the same time. With Classic, it is possible for all three interferometers to look the same direction simultaneously. Actually, it is not of much use for all three interferometers to look at the same target, but the guide interferometers can use reference stars much closer to the target star. It is not clear that the larger angles between reference stars and science stars for SOS will reduce the precision however, but the additional constraint does make the geometric layout of the collectors more complicated for SOS.

On the other hand, for SOS, the collectors are forced to be close together, which to some extent simplifies the layout of the rest of the flight system. Although it is not a very clear advantage, there does appear to be somewhat more overall configuration layout freedom in the SOS architecture. Since Classic tends to drive the design towards fixed collectors, this then constrains the collectors to be arranged over a fairly large physical extent. This provides less freedom to layout the geometry within the fairly tight volume of the launch vehicle fairing. On the other hand, the fairly large pods of SOS impose a different difficulty in this process of laying out the system to fit inside the fairing. The relatively large radial extent leaves less room to place structure around the pods.

To be fair, it was very challenging to find solutions for both layouts. When the layouts shown in the figures above were initially conceived, the launch vehicle was a Delta II 7920. Recently, the project made a different architectural choice. It was decided to avoid the difficulties of operating an observatory in low earth orbit and instead to use an earth-escape heliocentric orbit. This requires a larger, albeit more expensive, launch vehicle (Delta III class) which happens to have a larger fairing. This change greatly eases the difficulties of packaging a 10 meter class precise structure. This decision also simplifies many other aspects of the mission, such as earth and moon avoidance, solar power collection, attitude control, sun

baffle design. Now that a larger fairing is available, the layout of either Classic or SOS would be eased, and so the relative merit of this geometric size issue is reduced now.

When it is necessary to change the baseline, as in imaging, then Classic must use its switchyard mirrors to reconfigure the various collector pairs to form new interferometers. This means it is necessary to lose lock on at least one star at a time during the process. For SOS, there is a chance that the interferometers can remain operating and locked onto their stars while the pod of collectors is moved. This is not essential, and would increase the precision required of the trolley system, but it would enable an increase in observational efficiency since it would eliminate the time required to reacquire stars. This is not likely to be a major consideration since the overall time spent acquiring stars is a small fraction of the total observational time. However, it is a small advantage for SOS in that it allows some additional design freedom.

The decoupled fiducials for Classic makes it possible to achieve the variable baseline required for imaging without the need to move the collectors laterally. The u-v plane is filled reasonably uniformly using the twenty-one combinations of the seven fixed collectors. SOS basically is driven towards a solution that requires the movement of at least one large assembly of four collectors. Although a design concept has been developed to achieve this, the implementation is likely to be complicated.

With the moving trolley needed for SOS, it was quite challenging to achieve very small baselines (0.5 m). The difficulty arose since the physical size of the pod size to house four collectors is on the order of 2 m in linear dimension. It isn't very feasible to move the two collector pods closer than a physical separation of 2 m. In order to achieve 0.5 m astrometric baseline, it was necessary to include a collector that could be aimed only 15 degrees away from the physical baseline. Although this obstacle now appears to have been overcome, it is an additional constraint in the already complicated layout of four collectors in a pod. As the design evolves to meet challenges not yet recognized, this factor is a negative aspect. For Classic, it is quite easy (in comparison) to achieve small baseline. One simply places two of the collectors side by side, limited only by the physical size of the mirrors and their mounting means.

Another constraint favoring Classic is the freedom to point the line of sight independent of the translation. For SOS, the collectors have to translate very precisely over a range of about 30 cm in order to keep the center of the line of sight aimed at the fiducial whenever the line of sight must be tilted. Although Classic does need some translational stages to maintain alignment, the tilt is essentially independent of the translation. Classic can aim its collectors by simply tilting them (or as selected for the particular point design, by a tip-tilt mechanism with a flat siderostat mirror). The SOS design choice is a hexapod consisting of six linear actuators with rather stringent precision requirements over a range of motion of many centimeters. Other options are available, but still, it is basically inherent in the architecture that this pointing aspect is easier to implement for Classic.

The layout of the configuration of a space vehicle is affected by very many factors. Just a few have been mentioned here. The trade study that was performed to ultimately choose between the two architectures described here, SIM Classic vs Son of SIM, took several months, culminating in a two-day long review to a very experienced panel of scientists, engineers, and managers. The decision was made considering the viewpoints of all of the above and was a very difficult decision. Had there been a blatantly obvious difference between the two, the decision would have been much easier. In fact, it probably would not have required the two day review, nor such a protracted investigation. However, at the end of the two days, and after hours of debate, the decision was made in favor of SOS. Although there were presentations from many areas, for the most part, there were no overwhelmingly compelling reasons to select one versus the other. The single major exception was the external metrology system required for Classic. The assembly of thirty-four precision laser interferometer gauges stuck out literally like a sore thumb. It is clear that this single factor ultimately tilted the scale in favor of SOS.

5 SUMMARY

A brief description has been presented of two architectures each of which could achieve the science objectives of the Space Interferometry Mission, SIM. Point designs for both architectures have been

contrasted and some of the pros and cons have been discussed. It is not feasible to create a comprehensive list of all the differences, nor would it be helpful. The main point has been to illustrate that there are many factors that can influence the choice between two fairly attractive options. The rationale for the selection of SOS over Classic has been explained, at least partially. The decision was difficult, but having made it, the SIM project can now move ahead with renewed vigor on a challenging but rewarding course towards a successful mission.

6 ACKNOWLEDGEMENT

This work was carried out by the Jet Propulsion Laboratory, California Institute of Technology under a contract with the National Aeronautics and Space Administration.

SIM Configuration Trades

Kim Aaron

William H. Mateer II

Richard Baron

SPIE Astronomical Interferometry Conference

March 20, 1998

Outline

- Current SIM Configuration Overview
- Previous SIM Configuration Overview
- Comparison of Configurations and Rationale for Selection
- Summary

Current SIM Configuration



Previous SIM Configuration

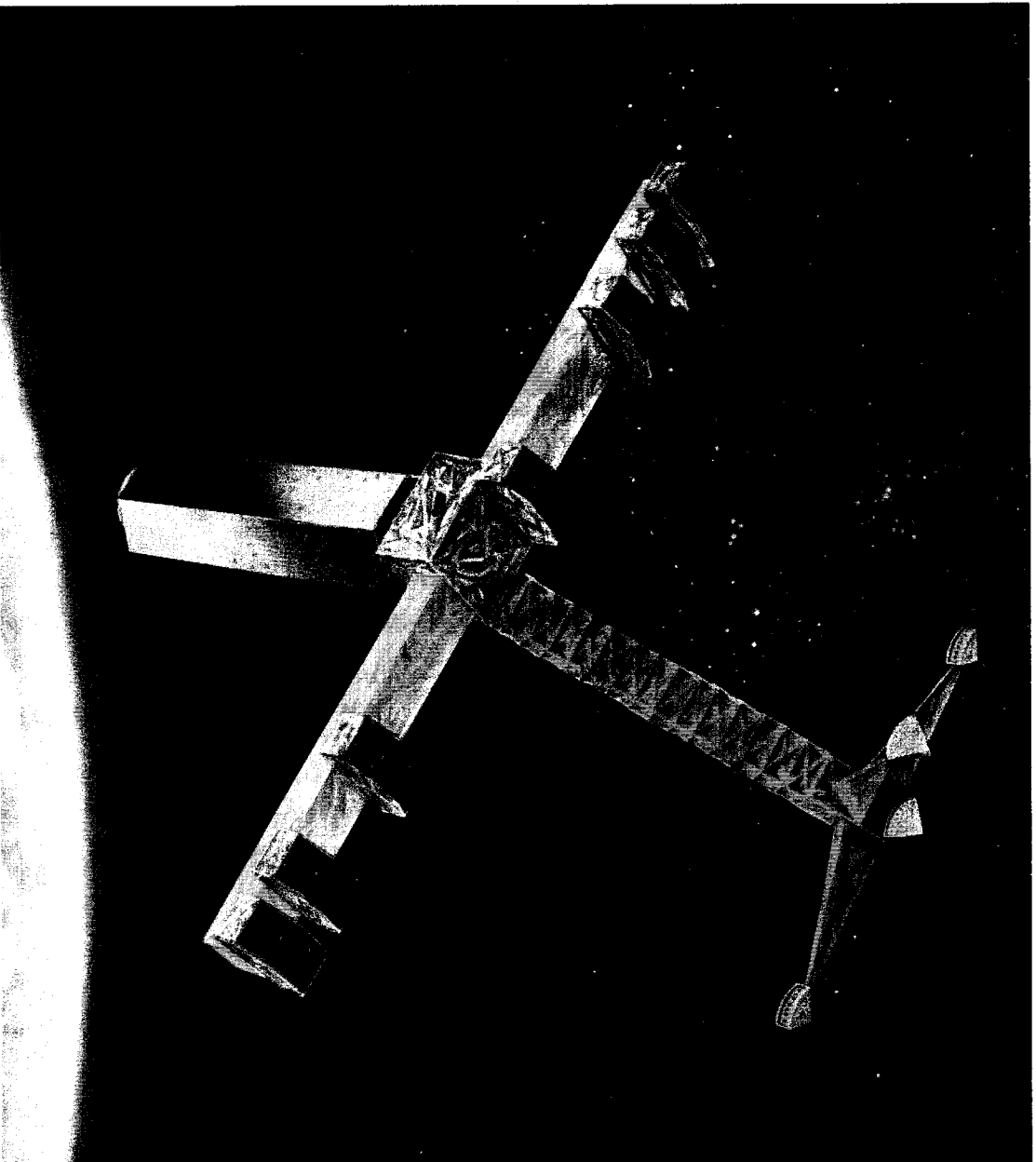

Comparison of Features

Feature	Classic Implementation	SOS Implementation
Clear Aperture	0.33 m	0.33 m
Angular Resolution	4 μ arc sec	4 μ arc sec
Max Baseline	10 m	10.7 m
Min Baseline	0.4 m	0.5 m
Baseline Variation Technique	Seven Collectors with Optical Switchyard	Eight Collectors (four pairs) with trolley on track
Pointing	2 dof Siderostat flat	6 dof Hexapod Compressor
Baseline Fiducials	Corner cube in center of each siderostat flat mirror	Two multiple corner cubes in FOV of all interferometers
External Metrology (to measure locations of fiducials)	34 laser interferometers between 11 corner cubes	One laser interferometer between two corner cubes

SOS Optics Layout

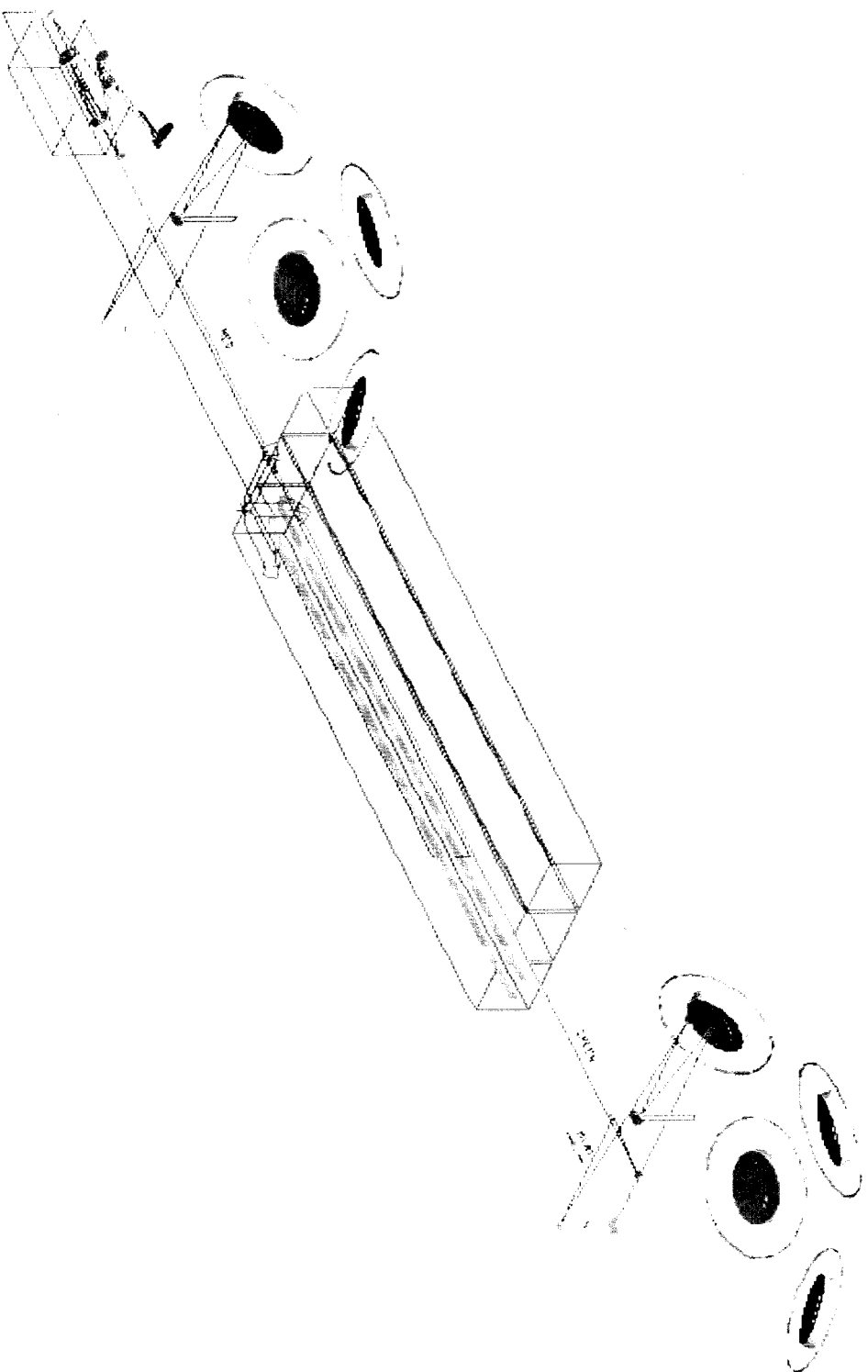

SIM Classic Optics Layout

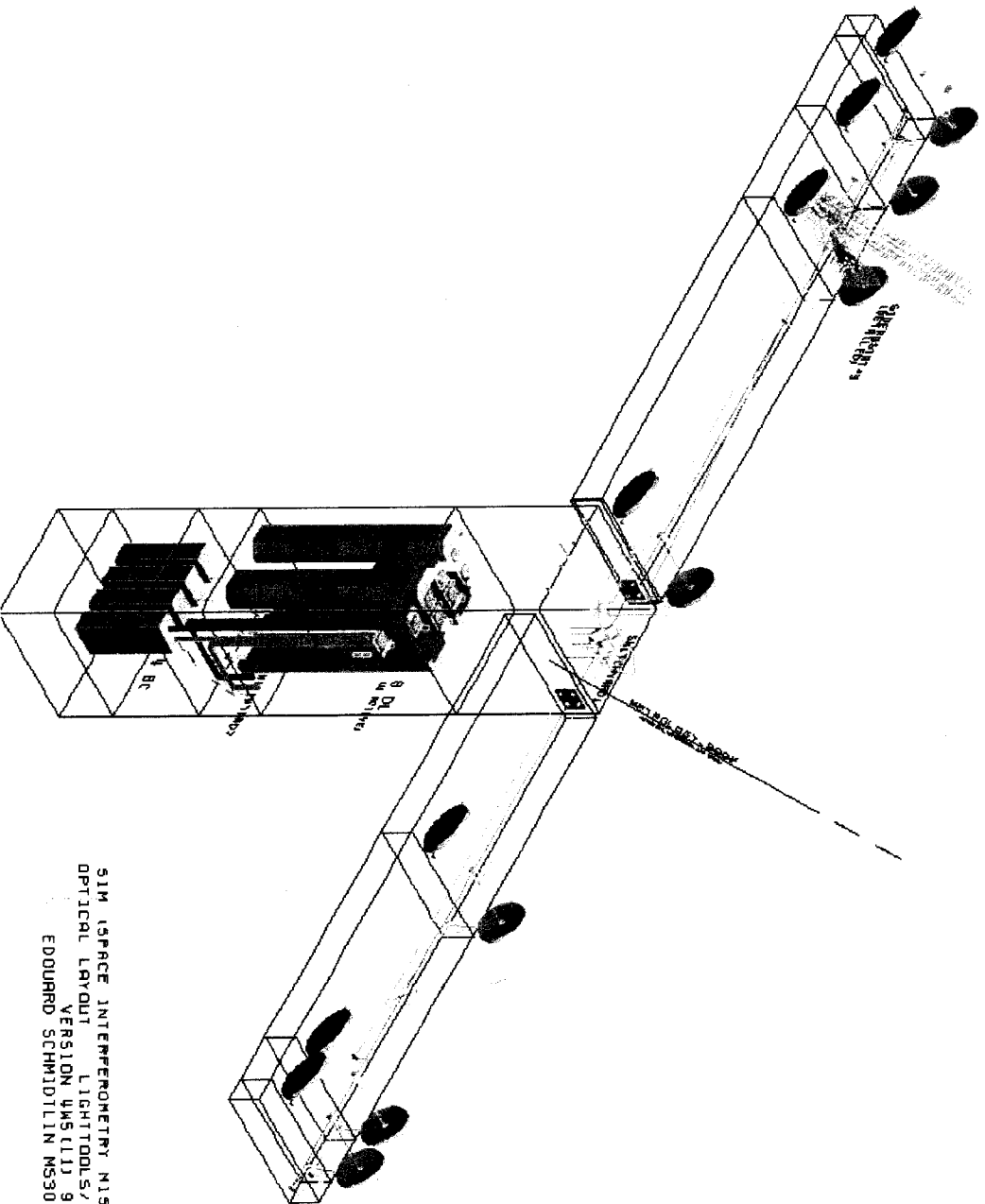

SIM (SPACE INTERFEROMETRY) MISSIOM)
OPTICAL LAYOUT LIGHTTOOLS/CODEV
VERSION 4M5111 9MAY96
EDOUARD SCHMIDTILIN NS306-388

Summary

- Comparison of recent SIM architectures
- Selection Driven predominantly by Reduced Complexity of External Metrology
- Overview of *Current* Configuration
 - This is very dynamic (expect changes soon)